

Photoadditions of Aromatic Compounds

J. J. MCCULLOUGH

101 Governor's Road, No. 318, Dundas, Ontario, Canada L9H 6L7

Received September 29, 1986 (Revised Manuscript Received May 4, 1987)

Contents

I. Introduction	811	C. Mixed Photoadditions of Acenaphthylene, Phenanthrenes, Stilbenes, and Styrene Derivatives	833
II. Primary Processes	812	1. Acenaphthylene	833
A. Excimer and Exciplex Formation	812	2. Indene	833
1. Kinetic Scheme for Bimolecular Exciplex Formation	813	3. Stilbenes	834
2. Pyrene Excimer	814	4. Phenanthrenes	835
3. Aromatic Hydrocarbons and Dialkylaniline Derivatives	814	IV. Exciplexes as Reaction Intermediates	835
4. Effect of Donor-Acceptor Properties on Quenching Rate	815	A. Experimental Evidence	835
5. 1-Naphthonitrile-Alkene Exciplexes	816	B. Exciplex Formation, Decay, and Potential-Energy Surfaces	838
6. Temperature Dependence of Exciplex Formation	816	V. Photokinetics and Photochemistry of Bichromophoric Compounds	839
B. Bonding and Stabilization of Excimers and Exciplexes	818	A. Effects of the Linking Chain	839
C. Exciplex Formation in Polar Solvents	818	1. General Considerations	839
1. Solvent Effects on Fluorescence Wavelength	818	2. Effect of Chain Length on Exciplex Formation	841
2. Exciplex Decay Processes in Polar Solvents	819	B. Effects of Linking Chain on Photoaddition Reactions	841
D. Excited-State Electron Transfer: Thermodynamics, Kinetics, and Theoretical Aspects	820	1. Systems with Three-Atom Chains	841
1. Thermodynamics	820	2. Linked Phenyl and Alkene Groups	842
2. Theory and Kinetics	820	3. Chromophores Linked with Two-Atom Chains. Cyclophanes	843
III. Photoadditions of Aromatic Compounds	822	VI. Excited-State Electron Transfer	845
A. Dimerization	822	A. Reactions of Radical Ions and Ion Pairs	845
1. Anthracene and Derivatives	822	1. Reactions Involving Solvent	845
2. Naphthalene Derivatives	823	2. Cyclobutane-Forming Additions	847
3. Formation of Cyclobutane Dimers	824	3. Bond-Cleavage Reactions and Retroadditions	849
4. Phenanthrene and Derivatives	824	4. Cosensitized Electron Transfer	850
5. Styrene-Like Systems	825	5. Photochemistry of Iminium Salts	850
6. Cinnamic Acid and Derivatives	826	VII. Photoadditions of Heterocyclic Compounds	851
B. Photoaddition of Aromatic Compounds to Alkene Derivatives (Mixed Additions)	827	A. Pyrrole and Indole Derivatives	851
1. Monocyclic Aromatics	827	B. Pyridine and Quinoline Derivatives	852
2. Mechanistic Aspects of the Addition of Benzene and Ethylenic Compounds	828	C. Furan and Thiophene Derivatives	854
3. Exciplexes and Benzene Photoadditions	829	D. Oxazole and Thiazole Derivatives	855
4. Addition of Ethylenic Compounds to Naphthalenes	829	VIII. Addenda	856
5. Naphthalene and Acetylene Derivatives	831	IX. References and Notes	856
6. Carbonyl Compounds. 1,2- and 1,4-Additions	831		
7. Addition of Benzene, Naphthalene, and Anthracene to Dienes and Trienes	832		

I. Introduction

Many organic reactions are conveniently discussed in terms of the reactive intermediates involved. Cations, anions, free radicals, carbenes, and nitrenes are examples of well-known intermediates. Once the nature and properties of intermediates in a given reaction have been established, interpretation and prediction of kinetics, products, and stereochemistry becomes possible.

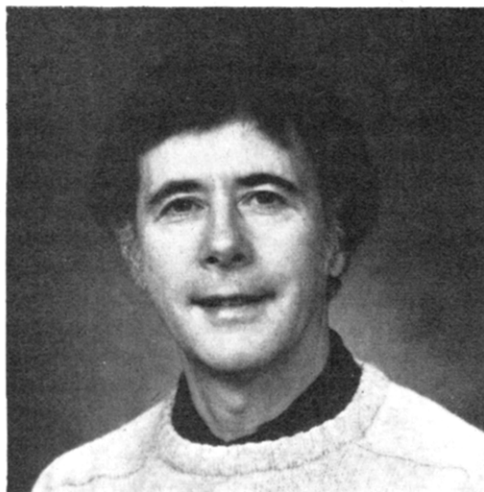

John J. McCullough was born and educated in the United Kingdom, where he attended the Methodist College and Queen's University, Belfast. He graduated with honors in chemistry (B.Sc., 1959) and did graduate work in the field of stereochemistry (Ph.D., 1962). He is Professor of Chemistry at McMaster University, Hamilton, Ontario, Canada. His research has been mainly in the field of organic photochemistry, and this interest resulted from visits to the United States—as a postdoctoral fellow and on sabbatical leave. He is a member of the American Society for Photobiology, Sigma Xi, and the President's Club of McMaster University. His nonscientific activities include sports, hiking, and travel.

We have been interested in the intermediates of photochemistry, including biradicals,¹ biradicaloids,² excited-state complexes,^{3,4} and ion pairs,^{5,6} which we have investigated using their chemical reactions as well as the physical techniques available to us. Some of these intermediates can only be generated photochemically, and relating their properties, e.g., decay kinetics, to the overall chemistry is an intriguing area of research.

One of the first schemes proposed for a photoaddition reaction explained the addition products of 2-cyclohexenones and substituted ethylenes in terms of excited-state complexes and biradical intermediates.⁷ We used a similar scheme to interpret the stereochemistry of 4,4-dimethyl-2-cyclohexenone additions to cyclopentene.⁸ However, the above schemes^{7,8} were based almost entirely on structures of products. Mechanistic work is difficult to carry out; neither the excited-state (triplet) nor the proposed intermediate complex emit in solution. Also, the biradicals have not been observed directly in this reaction, although there is reasonable chemical evidence that they exist.¹ The scheme proposed by Corey et al.⁷ is shown below.

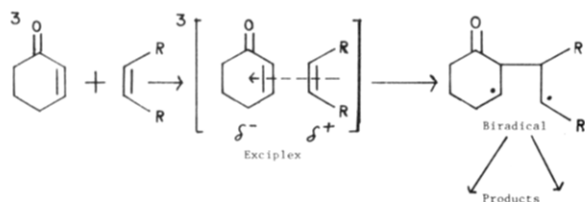

The most detailed picture of the mechanism of photoadditions has been deduced from singlet-state reactions, and we have employed naphthalene derivatives in our work.^{3-6,14} They absorb at accessible wavelengths, can be triplet sensitized, and the singlets have relatively long lifetimes (fluorescence lifetime of naphthalene is ~ 100 ns in many different solvents⁹).

The observation of exciplex fluorescence from 1-

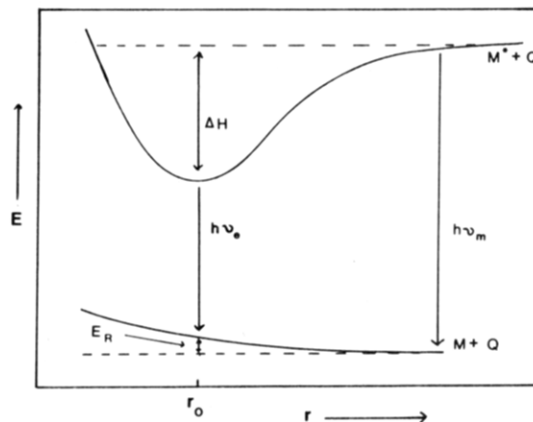

Figure 1. Potential energy profiles for the ground and excited states of M and Q, showing energy (E) as a function of intermolecular separation (r). Monomer and exciplex fluorescence are $h\nu_m$ and $h\nu_e$, respectively.

cyanonaphthalene-tetraalkylethylene systems¹⁰ and the development of transient kinetics using single-photon counting have resulted in the measurement of many rate constants for the formation and decay of photochemically reactive exciplexes.

Singlet excited states also undergo electron transfer to other molecules under suitable conditions, forming ion pairs, which have their own physical and chemical properties.^{5,6} Thus the photophysics and photochemistry of singlet excited states comprise a large field that is encountered in many other branches of pure and applied chemistry.

In the next section, the primary processes of excimer (exciplex) formation and electron transfer are described. Selected examples will be used to show how kinetic and thermodynamic data is obtained, and these examples will be useful in the discussions of photochemistry, found in later sections of the review.

II. Primary Processes

A. Excimer and Exciplex Formation

Excimers and exciplexes are formed on reaction of a monomer excited state (M^*) with a ground-state molecule (M or Q , respectively).

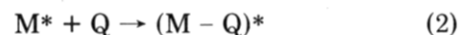

The potential-energy profile for these reactions is shown in Figure 1. Because of the exciplex stabilization energy (ΔH°) and ground-state repulsion (E_R), the exciplex fluorescence occurs at longer wavelengths than that of monomer. Excimers and exciplexes are in fact defined as "excited molecular complexes of definite stoichiometry, which are dissociative in the ground state".

Observation of a broad, long-wavelength fluorescence band (a typical example is shown in Figure 2) is unequivocal evidence that excited complexes are formed. However, not all exciplexes emit fluorescence,³ and we can classify these complexes into three groups:¹² (a) those that emit but do not react chemically; (b) those that do not emit but do react chemically; and (c) those that emit and also react chemically.

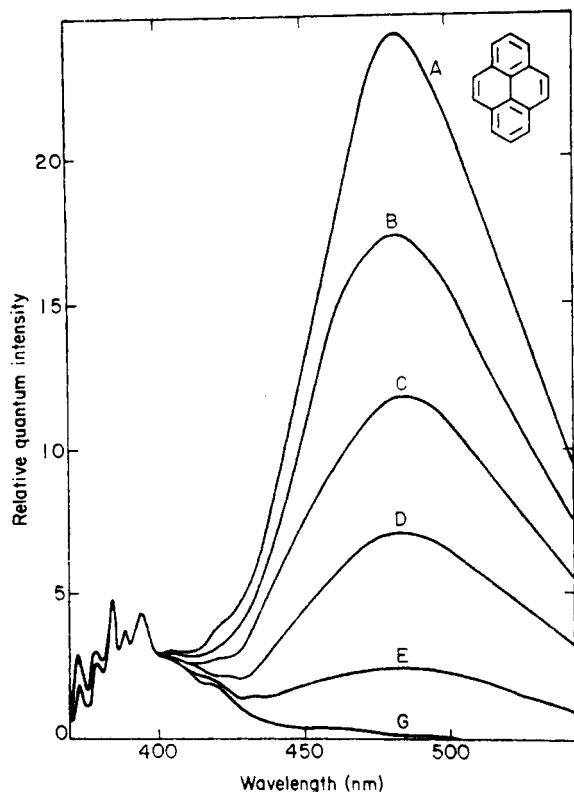

Figure 2. Fluorescence of pyrene solutions in cyclohexane: (A) 10^{-2} M; (B) 7.75×10^{-3} M; (C) 5.5×10^{-3} M; (D) 3.25×10^{-3} M; (E) 10^{-3} M; (G) 10^{-4} M. The long-wavelength concentration-dependent band is due to the excimer. From ref 13, p 302.

Most exciplexes belong to groups a and b, but members of group c, though less numerous, are important in that they allow photochemistry and photophysics to be correlated. In the following sections, the general kinetic scheme for exciplex formation, the method of analysis, and data obtained are described. These principles are illustrated by three examples of exciplexes for which fairly complete kinetic schemes have been determined and which will be used later in discussing photochemical reactions.

1. Kinetic Scheme for Bimolecular Exciplex Formation

Formation of excimers and exciplexes results in quenching of the excited state that forms them, just as energy or electron transfer does. In the absence of ground-state interactions, the extent of quenching is related to the quencher concentration by the well-known Stern-Volmer equation (3). Φ_0^F and Φ^F are the

$$\Phi_0^F / \Phi^F = (I_0 / I) = 1 + K_{SV}[Q] \quad (3)$$

unquenched and quenched fluorescence quantum yields, I_0 and I are the corresponding intensities, and $[Q]$ is the quencher concentration. K_{SV} is the slope of the Stern-Volmer plot, which is linear even with complex excited-state kinetics. Equation 3 holds for fluorescent and nonfluorescent exciplex formation, just as it does for other processes derived from M^* , such as chemical reactions.

The relationship between $[Q]$ and quantum yield of exciplex fluorescence (Φ_E), or other processes derived

$$\Phi_E^{-1} = \Phi_{E(\text{lim})}^{-1} (1 + K_{SV}^{-1}[Q]^{-1}) \quad (4)$$

from the exciplex, is given by eq 4. $\Phi_{E(\text{lim})}$ is the ex-

SCHEME I

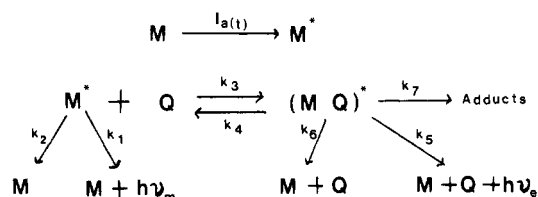

ciplex fluorescence quantum yield at infinite $[Q]$, where all the M^* molecules are quenched, and only those processes derived from the exciplex are important. The intercept of (4), where $[Q]^{-1} = 0$, gives $\Phi_{E(\text{lim})}$, which is called the limiting quantum yield.

A general kinetic scheme for exciplex formation in nonpolar solvents is given in Scheme I.¹¹ Using this scheme, the quantities above, such as K_{SV} and $\Phi_{E(\text{lim})}$ can be expressed in terms of the individual rate constants.

The monomer lifetime in the absence of quenchers, τ_M , is given by eq 5.

$$\tau_M = (k_1 + k_2)^{-1} \quad (5)$$

To simplify the expressions, the exciplex decay processes can be grouped together to give eq 6. In some

$$k_5 + k_6 + k_7 = k_p \quad (6)$$

cases additional rate constants for intersystem crossing would be added to the above, but this would not change the kinetic expressions. Under certain conditions, $k_p^{-1} = \tau_E$, the observed exciplex lifetime. $I_a(t)$ is the intensity of the incident light, which is constant in steady-state experiments, or a pulse of light, in transient experiments.¹¹

The rate equations are

$$d[M^*]/dt = I_a(t) + k_4[(MQ)^*] - (k_1 + k_2 + k_3[Q])[M^*] \quad (7)$$

$$d[(MQ)^*]/dt = k_3[Q][M^*] - (k_4 + k_p)[(MQ)^*] \quad (8)$$

Use of the steady-state approximation gives the expression for K_{SV} (eq 9)

$$K_{SV} = \frac{k_3(k_5 + k_6 + k_7)\tau_M}{k_4 + (k_5 + k_6 + k_7)} \quad (9)$$

or

$$K_{SV}/\tau_M = k_3 k_p / (k_4 + k_p) \quad (10)$$

If $k_4 = 0$ or if $k_p \gg k_4$, then $K_{SV}/\tau_M = k_3$, and the quenching process is irreversible. This is frequently observed when, for example, $K_{SV}/\tau_M = k$ (diffusion).

The steady-state treatment also gives eq 11.

$$\Phi_{E(\text{lim})} = \frac{k_5}{k_5 + k_6 + k_7} = \frac{k_5}{k_p} \quad (11)$$

If $\Phi_{E(\text{lim})}$ and k_p can be measured, then k_5 can be obtained. A similar relationship relates the limiting quantum yield for product formation $\Phi_{p(\text{lim})}$ and k_7 (eq 12). Thus k_7 can be obtained from $\Phi_{p(\text{lim})}$ if k_p is known.

$$\Phi_{p(\text{lim})} = \frac{k_7}{k_5 + k_6 + k_7} = \frac{k_7}{k_p} \quad (12)$$

To obtain all the rate constants in Scheme I transient kinetics are required. That is, the decay kinetics of the

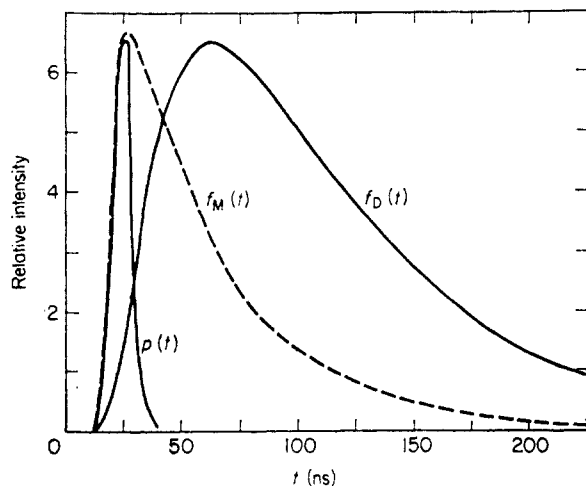

Figure 3. Fluorescence response of pyrene (5×10^{-8} M) in cyclohexane. Excitation pulse ($p(t)$), and monomer ($f_M(t)$) and excimer ($f_D(t)$) response functions are shown. From ref 13, p 305.

monomer and excimer fluorescence are determined after excitation with a pulse of light.^{11,13}

If $I_a(t)$ is a short light pulse at $t = 0$, $[M^*] = [M^*]_0$, and $[(MQ)^*] = [(MQ)^*]_0 = 0$, the solutions of eq 7 and 8 are

$$[M^*] = C_1 e^{-\lambda_1 t} + C_2 e^{-\lambda_2 t} \quad (13)$$

$$[(MQ)^*] = C_3 (e^{-\lambda_1 t} - e^{-\lambda_2 t}) \quad (14)$$

where

$$\lambda_{1,2} = \frac{1}{2} [k_1 + k_2 + k_3[Q] + k_4 + k_p \mp \{(k_4 + k_p - k_1 - k_2 - k_3[Q])^2 + 4k_3k_4[Q]\}^{1/2}] \quad (15)$$

The coefficients C_1 , C_2 , and C_3 are given by

$$C_1 = [(\lambda_2 - X)/(\lambda_2 - \lambda_1)][M^*]_0 \quad (16)$$

$$C_2 = [(X - \lambda_1)/(\lambda_2 - \lambda_1)][M^*]_0 \quad (17)$$

$$C_3 = k_3[M^*]_0[Q]/(\lambda_2 - \lambda_1) \quad (18)$$

where

$$X = k_1 + k_2 + k_3[Q] \quad (19)$$

The time dependencies of pyrene monomer and excimer fluorescence are shown in Figure 3. The monomer shows a continuous decrease, while the excimer shows a buildup to a maximum and then a decrease. Note that $[M^*]$ and $[(MQ)^*]$ would show similar response functions, according to the kinetics of Scheme I, since excimers are a special case where $Q = M$.

In our work on exciplex kinetics,¹⁴ we have found it useful to work at limiting quencher concentration, which in practice means at least 95% quenching of monomer fluorescence.

As $1/[Q] \rightarrow 0$, eq 15 gives¹¹

$$\lambda_1 = k_1 + k_2 + k_3[Q] \quad (20)$$

$$\lambda_2 = k_4 + k_p \quad (21)$$

From (14) and (18), $[(MQ)^*]$ is given by

$$[(MQ)^*] = [(M^*)]_0 e^{-(k_4 + k_p)t} \quad (22)$$

Thus, at infinite $[Q]$, the exciplex decay approximates to a single exponential, with decay constant $\lambda = k_4 + k_p$. If $k_4 \ll k_p$, such as at low temperature, the decay

constant is k_p . In the case of rapid equilibrium between excited monomer and exciplex (the high-temperature limit¹¹), the decay constant λ is also $= k_p$.¹⁴ It was also shown by comparison of data obtained at limiting quencher concentration¹⁴ with that from a more detailed study¹¹ that the above approximations are reasonable, and this approach should prove useful in future work.

Some systems that have been studied by steady-state and transient kinetics will be considered next.

2. Pyrene Excimer

Pyrene was the first organic molecule observed to form a fluorescent excimer in solution, and the spectra, which are typical of other excimers and exciplexes, are shown in Figure 2. This system has been studied extensively,^{13,15-17} and the reaction is shown in eq 23.

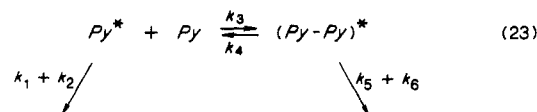

The symbols used correspond to the various processes shown in Scheme I. The kinetic scheme has features now well-known in other exciplex systems.^{11,14} The forward rate constant (k_3) is diffusion controlled and depends on solvent viscosity ($k_3 = 6.7 \times 10^9$ M⁻¹ s⁻¹ in cyclohexane). The rate constant (room temperature) for excimer dissociation is 0.65×10^7 s⁻¹.

The pyrene excimer is now well characterized and has been used to study the effects of linking the monomer units with a saturated chain. This work is discussed section V.

3. Aromatic Hydrocarbons and Dialkylaniline Derivatives

Work with aromatic hydrocarbons and *N,N*-dialkylaniline derivatives¹⁸ has provided much information on the formation and properties of unsymmetrical polar exciplexes. The excited molecule (usually the hydrocarbon) is quenched by the electron-donating amine, resulting in formation of a charge-transfer (CT) complex or an ion pair, depending on the solvent. The complexes are formed in nonpolar solvents and often show broad, red-shifted fluorescence, similar to that of the pyrene excimer. The ion pairs are formed in polar solvents; they are nonfluorescent and will be considered later.

Since the discovery of the pyrene-dimethylaniline exciplex,¹² many studies of these kinds of complexes have been carried out.¹⁸⁻²³ Solvent effects show that the complexes are very polar, which is consistent with the molecular orbital description²³ shown in Figure 4. From the energy levels involved, conversion of the ground-state pair ($A + D$) to the exciplex involves transfer of an electron from D to A and is related to the oxidation and reduction potentials of D and A . Thus, it was found that the energy of the exciplex fluorescence maximum ($h\nu_e^{\max}$) was related to the oxidation potential $E(D/D^+)$ of the donor and reduction potential $E(A^-/A)$ of the acceptor for a large number of donor-acceptor complexes.^{11,21} The following relationship (eq 24) was found. This is an empirical relationship, since the

$$h\nu_e^{\max} = E(D/D^+) - E(A^-/D) - 0.15 \text{ eV} \quad (24)$$

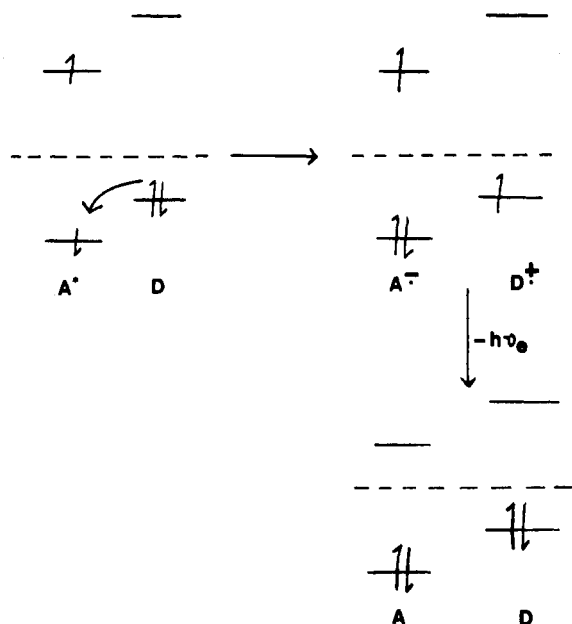

Figure 4. Molecular orbital description of a polar exciplex, formed from an excited acceptor (A^*) and ground-state donor (D).

oxidation and reduction potentials refer to solvated ions, and $h\nu_e$ is for nonpolar solvents. However, the proportionality between $h\nu_e^{\max}$ and $E(D/D^+) - E(A^-/A)$, expected from the molecular orbital model, is clear from the plots obtained.^{21,22}

4. Effect of Donor-Acceptor Properties on Quenching Rate

In many systems, it is found that the quenching rate, measured by the Stern-Volmer slope (K_{SV}/τ), also depends on the donor-acceptor properties of the excited molecule and the quencher. This is also observed when complete electron transfer occurs, giving ion pairs. Electron transfer has been very widely studied. Charge-transfer complex formation dependence on donor-acceptor properties has been the subject of some controversy in the literature and is not as well understood as electron transfer. Since these complexes are important in photoaddition reactions, the quenching work will be briefly discussed.

A number of cases of fluorescence and triplet quenching are known, which for energetic reasons cannot involve energy transfer or ion-pair formation. These include quenching of naphthalene excited states^{24,25} by amines and electron acceptors such as carbon tetrachloride and by alkene derivatives^{26,28} and the quenching of ketone triplets^{29,30} by electron donors such as amines. In many of these cases, no exciplex fluorescence is observed, but the quenching rate depends on the oxidation or ionization potential of the donor and the reduction potential of the acceptor molecule. A typical empirical relationship is shown in eq 25 and Figure 5 for the quenching of benzophenone

$$\Delta G_c(\alpha \log k_c) \approx -{}^3E_{0,0} + IP_D - E(A^-/A) + C \quad (25)$$

triplet by a series of electron donors in benzene solvent.

ΔG_c and k_c are the free energy and rate constant for exciplex formation, which is assumed to be a simple, bimolecular process. ${}^3E_{0,0}$, IP_D , and $E(A^-/A)$ are the triplet excitation energy, the donor ionization potential, and the acceptor reduction potential, respectively. C

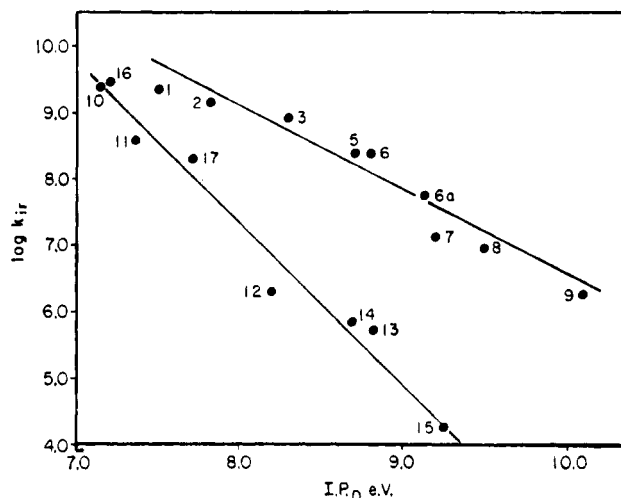

Figure 5. Relation of rate constant for quenching of benzophenone triplet in benzene (k_{ir}) to ionization potential of donor IP_D . Some quenchers used were (1) triethylamine; (3) di-*n*-butyl sulfide; (5) 2-butylamine; (6a) *cis*-2-butene; (8) di-*n*-propyl ether; (10) *N,N*-dimethylaniline; (12) anisole; (14) diphenyl ether; (17) 1-azabicyclo[2.2.2]octane. Data from ref 29.

is a constant that depends on several factors, such as the nature of the solvent.

The plots in Figure 5 show that k_c decreases over four powers of ten as IP increases. The data lie on two lines, one for aliphatic donors, the other for aromatics. The slopes of -0.067 and -0.105 mol/kcal are much lower than the value observed in systems where complete electron transfer occurs (0.74)³¹ and are consistent with formation of moderately polar complexes rather than ion pairs. Similar trends have been observed in other systems.²⁶⁻²⁸

A similar correlation was observed for a series of alkylnaphthalenes as fluorescers quenched by acrylonitrile in 95% ethanol.³² Figure 6 shows the relationship between K_{SV}/τ (which equals k_c for irreversible quenching) and the sum of the Hammett substituent constants (σ) for alkyl substitution. Charge development on the naphthalene ring in the quenching reaction will result in a linear free energy relationship, such as eq 26. This assumes that changes in the singlet exci-

$$\log (K_{SV}/\tau) = \log k_c = A + \rho \sum(\sigma) \quad (26)$$

tation energies throughout the series of alkylnaphthalenes are relatively small.

The negative slope $\rho = -1.613$ shows that partial positive charge does develop on the naphthalene ring in the species formed on quenching. Unit positive charge, such as in ion-pair formation, would require a more negative slope.

Thus, it was concluded that quenching of this series of naphthalenes by acrylonitrile is due mainly to (nonemitting) complex formation. This is interesting in view of the polar nature of the solvent used (95% ethanol), in which ion-pair formation is also a real possibility. However, we also observe that the points for 1-methyl- and 2-methylnaphthalene, 2 and 3, respectively, are at different positions on the above plot, even though the ionization and oxidation potentials of these compounds are the same.^{33,34} This supports the conclusion that the quenching rate is determined by formation of a complex and not an ion pair.

Although many of the above correlations have been observed, it is not clear exactly why they exist. The

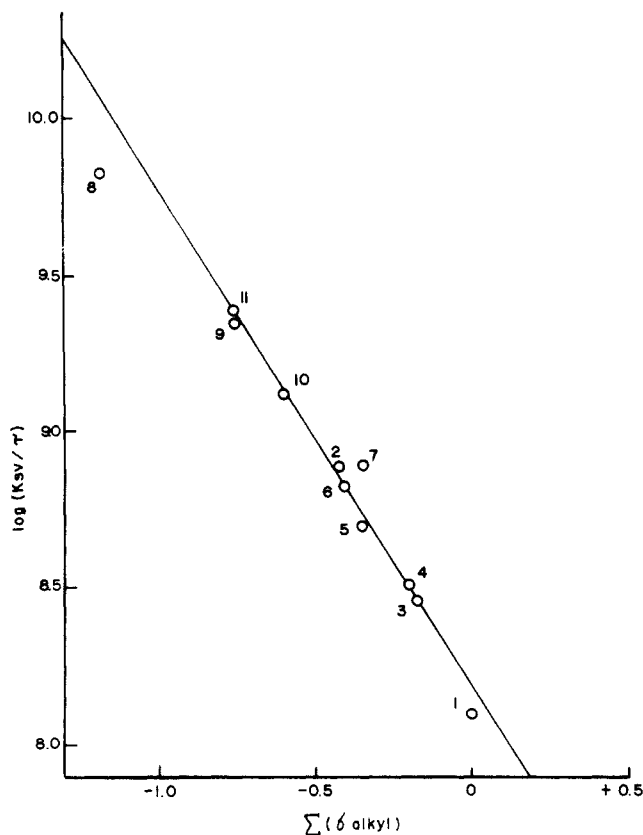
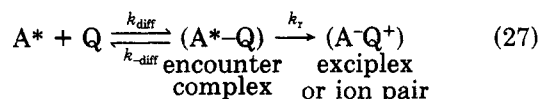

Figure 6. Hammett plot of quenching rate for a series of naphthalenes (fluorescers) by acrylonitrile in 95% ethanol. Fluorescers were (1) naphthalene; (2) 1-methylnaphthalene; (3) 2-methylnaphthalene; (4) 2-*tert*-butylnaphthalene; (5) 2,6-dimethylnaphthalene; (6) 2,6-di-*tert*-butylnaphthalene; (7) 2,3-dimethylnaphthalene; (8) 1,2,3,4-tetramethylnaphthalene; (9) 1,2,3-trimethylnaphthalene; (10) 2,3,6-trimethylnaphthalene; (11) 2,3,5-trimethylnaphthalene. Data from ref 32.

Stern–Volmer slope gives K_{SV}/τ , which is usually not a simple bimolecular rate constant but a function of several rate constants (eq 9). In a case where all the rate constants for reversible complex formation (Scheme I) could be determined (see below), Ware and co-workers¹¹ found no correlation of either exciplex lifetime ($(k_5 + k_6 + k_7)^{-1} = \tau_E$) or of k_3 with ionization potential of the olefin quenchers. The rate constant for exciplex dissociation, k_4 , did correlate with ionization potential of the quencher, although not many compounds were used and the range of IP's covered was only 1 eV.

Some time ago Evans²⁸ proposed a kinetic model for singlet quenching that is similar to the scheme used to interpret formation of a solvated ion pair (section II.D). In this model, an encounter complex is formed reversibly by diffusion, and this complex then forms a solvated ion pair or a contact ion pair (exciplex) irreversibly. The reaction is shown in eq 27.



The rate constant for diffusion of A^* and Q to form the encounter complex is k_{diff} , while k_{-diff} is the rate at which they diffuse apart. k_r is the rate constant of exciplex or ion-pair formation. Use of the steady-state approximation gives the following expressions (eq 28)

for the slope of the Stern–Volmer plot (eq 3).

$$K_{SV}/\tau_{A^*} (=k_q) = k_{diff}k_r/(k_{diff} + k_r) \quad (28)$$

$$k_r/k_{diff} = k_q/(k_{diff} - k_q) \quad (29)$$

Since k_q can be measured and k_{diff} calculated, the ratio k_r/k_{diff} can be determined. If k_{diff} is approximately constant for a given solvent, then

$$\log k_r/k_{diff} = \log \left(\frac{k_q}{(k_{diff} - k_q)} \right) \propto \Delta G^\ddagger \quad (30)$$

where ΔG^\ddagger is the free energy of activation for the electron-transfer process. For a constant fluorescer (acceptor) and series of quenchers (donors), $\Delta G^\ddagger \propto IP + C$, where IP is the ionization potential of the donor and C is a constant depending on solvation. The function $\log [k_q/(k_{diff} - k_q)]$ was found to be proportional to IP for the fluorescence quenching of acridine by a series of amines in water, for 2,3-diazabicyclo[2.2.2]oct-2-ene by alkenes and dienes in isooctane, and for naphthalene by alkenes and dienes in hexane.

Since the acridine fluorescence quenching is known to be due to electron transfer and the other two cases show the same dependence on quencher ionization potential, it was concluded that charge-transfer effects were important in determining the quenching rate in all three cases. Note that in the quenching of 2,3-diazabicyclo[2.2.2]oct-2-ene and naphthalene by alkenes and dienes in alkane solvents the proposed exciplexes are nonfluorescent, not particularly stable, and presumably short-lived. A direct comparison with the fluorescent, more stable and longer lived exciplexes (such as the 1-naphthonitrile–alkene exciplexes) is probably not valid.^{26,27}

5. 1-Naphthonitrile–Alkene Exciplexes

Several aryl nitriles form fluorescent exciplexes with alkenes, which have been studied by using steady-state³⁵ and transient^{11,36–38} methods. These exciplexes are important photochemically since they are intermediates in various reactions, particularly the $\Pi_{2s} + \Pi_{2s}$ cycloaddition,¹⁴ and the photochemistry will be discussed later. The most detailed kinetic work is that of Ware and co-workers on the 1-naphthonitrile–alkene exciplexes, which has shown that the processes summarized in Scheme I are sufficient to describe the photokinetics at different temperatures and in nonpolar and medium polarity solvents. Both monomer and exciplex fluorescence are observed,³⁵ as shown in Figure 7, and both fluorescence bands can be used for transient measurements. Since the transient kinetics observed depend on the temperature of the system, we will briefly consider the temperature dependence of exciplex formation.

6. Temperature Dependence of Exciplex Formation

The variation of exciplex:monomer fluorescence intensity ratios with temperature was observed some time ago by Weller and co-workers²⁰ and was used to determine enthalpies of exciplex formation for arene-aromatic amine exciplexes. Naphthonitrile–alkene exciplexes show similar behavior, and an example from

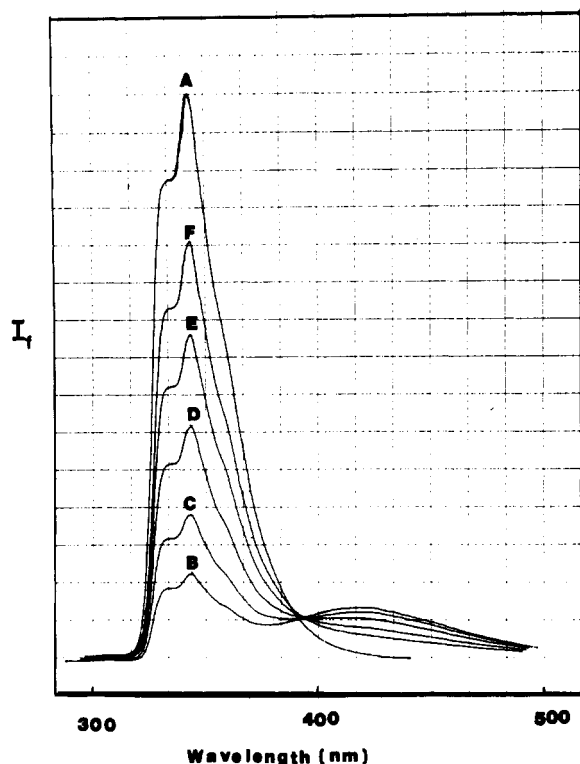

Figure 7. Fluorescence of 2-methyl-1-naphthonitrile-tetramethylethylene in ethyl acetate. Alkene concentrations were (A) 0, (B) 0.12 M, (C) 0.063 M, (D) 0.032 M, (E) 0.016 M, and (F) 0.0079 M. Monomer fluorescence was λ_{\max} 350 nm, exciplex λ_{\max} at 420 nm. Isoemissive point is at 390 nm. From the work of MacInnis (ref 14).

our work is shown in Figure 8.¹⁴ This kind of plot has been used frequently in photokinetic studies³⁹⁻⁴¹ and is characterized by two linear regions (at low and high temperatures), where $\log \Phi_E/\Phi_M$ is proportional to I/T , and a nonlinear region at intermediate temperatures. The plots shown in Figure 8 are typical and show that exciplex formation is reversible. The following analysis is often used, although the assumption that the monomer and exciplex lifetimes are independent of temperature is an approximation.

The ratio Φ_E^F/Φ_M^F is given by eq 31, where the rate

$$\Phi_E^F/\Phi_M^F = \frac{k_5}{k_1} \left(\frac{k_3[Q]}{k_4 + k_p} \right) \quad (31)$$

constants refer to Scheme I and $k_p = k_5 + k_6 + k_7$, i.e., k_p is the sum of all exciplex decay rates. Since k_4 is more temperature dependent than k_p , there will be two limiting temperature ranges.

If $k_p \gg k_4$, then we have eq 32.

$$\Phi_E^F/\Phi_M^F = \frac{k_5}{k_1} \left(\frac{k_3[Q]}{k_p} \right) \quad (32)$$

If $[Q]$ is constant, this gives eq 33.

$$\log (\Phi_E^F/\Phi_M^F) = \text{constant} - (E_{k_3}^{\text{act}} - E_{k_p}^{\text{act}})/RT \quad (33)$$

This gives the slope of the low-temperature linear region (right-hand side of Figure 8), which is determined by the difference of two activation energies, and exciplex formation is irreversible in this temperature range.

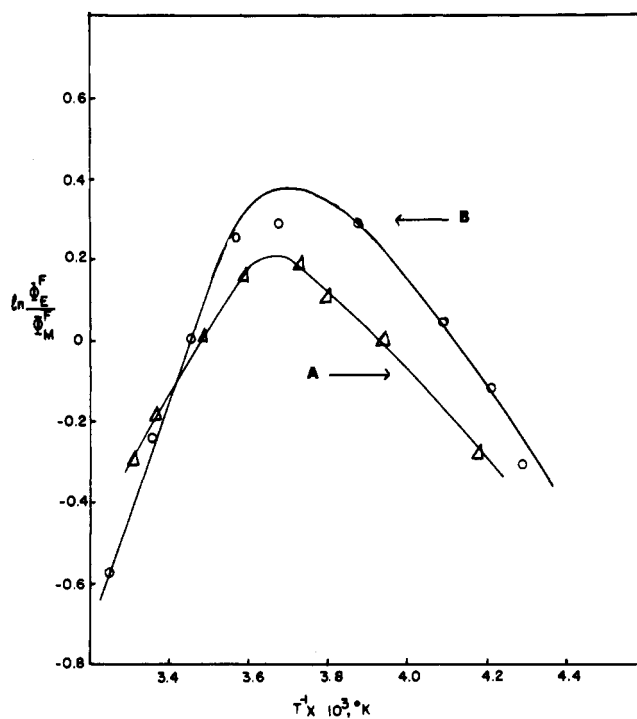

Figure 8. Temperature dependence of exciplex:monomer fluorescence ratios in ethyl acetate: (A) 4-methyl-1-naphthonitrile-tetramethylethylene; (B) 2-methyl-1-naphthonitrile-tetramethylethylene. Typical fluorescence spectra for the latter (B) are shown in Figure 7.

If $k_4 \gg k_p$, then at high temperatures the ratio of quantum yields (Φ_E^F/Φ_M^F) is given by eq 34.

$$\Phi_E^F/\Phi_M^F = \frac{k_5}{k_1} \left(\frac{k_3[Q]}{k_4} \right) \quad (34)$$

The ratio Φ_E^F/Φ_M^F is dependent on k_3/k_4 , which is equal to the equilibrium constant for exciplex formation (K_{ex}) and leads to eq 35, where ΔH_{ex} is the enthalpy of

$$\log (\Phi_E^F/\Phi_M^F) = \text{constant} - (\Delta H_{\text{ex}}/RT) \quad (35)$$

exciplex formation, which is given by the slope of the linear region at higher temperatures (left-hand side of Figure 8).

At intermediate temperatures (i.e., the concave-down section of Figure 8), k_4 and k_p are comparable, and the relationship between ΔH_{ex} and $\log (\Phi_E^F/\Phi_M^F)$ is nonlinear. Exciplex formation is partially reversible in this region, and monomer and exciplex fluorescence should both show double-exponential time dependence at these temperatures (eq 13 and 14).

Ware and co-workers have studied 1-naphthonitrile-alkene exciplexes in hexane, diethyl ether, and dimethoxyethane at various temperatures.^{11,36} At 25 °C, in hexane, 1-naphthonitrile-tetramethylethylene and 1-naphthonitrile-1,2-dimethylcyclopentene exciplexes are in the rapid equilibrium region. However, all the rate constants (Scheme I) can be obtained by combining transient and steady-state measurements.¹¹ At lower temperatures (0 to -40 °C), two-component monomer (1-naphthonitrile) fluorescence decay is observed, and all the rate constants can be obtained from transient measurements.^{36a} Some rate constants for hexane and diethyl ether are shown in Table I.

It can be seen that the rate constants for exciplex formation and decay (k_3 and k_p , respectively) are not

TABLE I. Rate Constants^a for 1-Naphthonitrile-1,2-Dimethylcyclopentene Exciplex Formation

<i>t</i> , °C	10 ⁻⁸ <i>k</i> ₃ , M ⁻¹ s ⁻¹	10 ⁻⁸ <i>k</i> ₄ , s ⁻¹	10 ⁻⁸ <i>k</i> _p , s ⁻¹
Solvent: Hexane ^b			
-0.3	98.8	1.11	0.98
-11	88.5	0.49	0.77
-13	66.7	0.11	0.52
Solvent: Diethyl Ether ^c			
20	120.7	0.248	0.648
10	108.0	0.168	0.538
0	92.9	0.054	0.439

^a Rate constants are labeled as in Scheme I. ^b Data from ref 36a. ^c Reference 36b.

very temperature or solvent dependent. However, *k*₄, the rate constant for exciplex dissociation, varies considerably with temperature. Note also that at 0 °C, *k*₄ is much smaller in diethyl ether than in hexane, while *k*₃ is similar in both solvents. Therefore, at this temperature, exciplex formation is irreversible in diethyl ether but partially reversible in hexane.^{11,36}

In a photokinetic study of 2- and 4-methyl-1-naphthonitrile and tetramethylethylene,¹⁴ we have found that the same scheme applies to these derivatives, but that the temperature ranges and exciplex stabilities are different from those of the corresponding 1-naphthonitrile exciplexes.

B. Bonding and Stabilization of Excimers and Exciplexes

Since their discovery, excimers and exciplexes have been the subject of several theoretical treatments.⁴²⁻⁴⁴ Two main factors are usually considered as the origin of bonding and stabilization in the excited complexes.⁴²⁻⁴⁵ These are excitation resonance between the monomer molecules and charge transfer from one monomer to another, respectively. For a singlet exciplex formed from a donor (D) and an acceptor (A), the contributors are shown in equation 36.

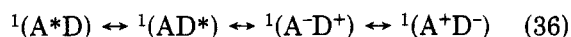

There has been some debate concerning the relative importance of these structures in various exciplexes.^{26,27,43} There is little doubt that one or other of the charge-transfer contributors can be very important when A and D are good electron acceptors and donors, respectively. In these cases, the exciplex has a large dipole moment, which is evidenced by the solvent effect on exciplex fluorescence (see below). There is also evidence, however, that charge-transfer contributors can also be important even when A and D are the same molecule (i.e., in an excimer).⁴⁶ Also interesting are the results of recent calculations,⁴³ which indicate that for the naphthalene-diene exciplexes excitation resonance is the major contributor, with charge resonance a minor component. These exciplexes are of the "moderately polar" type, which frequently do not emit but are chemically reactive, and will be mentioned again in the section on chemical reactivity (section IV).

In summary, both excitation and charge resonance can be important in determining the bonding and properties of excimers and exciplexes, but the relative contributions depend on the monomer units, the solvent,⁴⁵ and the exciplex geometry (e.g., restrictions im-

posed by linking the monomers with a saturated chain).⁴⁶

C. Exciplex Formation in Polar Solvents

Solvent effects on the electronic spectra of organic molecules are well-known and can be useful in characterizing various transitions. However, solvent effects on exciplexes, particularly those formed from donor-acceptor pairs, are extremely important and have provided much information on the intrinsic properties of exciplexes. Most work has employed nonpolar or very polar solvents (such as hexane and acetonitrile), but some studies have used medium-polarity solvents.

Two principal effects are observed as the solvent polarity is increased: the exciplex fluorescence shifts to longer wavelength and is quenched to an extent that depends on the solvent. This quenching is accompanied by a change in the exciplex lifetime.

1. Solvent Effects on Fluorescence Wavelength

The red shift of exciplex fluorescence in polar solvents can be explained by using the energy profile in Figure 1 and the molecular orbital model for polar exciplexes shown in Figure 4. Since the charge-transfer exciplex state (excited-state minimum in Figure 1) should be stabilized more than the ground state at this geometry, the energy of the transition is smaller and the fluorescence shifts to longer wavelength.

The wavelength shifts have been correlated with the solvent dielectric constant (ϵ) and the refractive index (n) by using eq 37.⁴⁷⁻⁴⁹ $\bar{\nu}_c$ and $\bar{\nu}_c(0)$ are the maxima of

$$\bar{\nu}_c = \bar{\nu}_c(0) - \frac{2\mu_c^2}{hca^3} \left(\frac{\epsilon - 1}{2\epsilon + 1} - \frac{n^2 - 1}{2n^2 + 1} \right) \quad (37)$$

$$\bar{\nu}_c = \bar{\nu}_c(0) - \frac{2\mu_c^2}{hca^3} (f_{(\epsilon)} - f_{(n)}) \quad (37a)$$

the exciplex fluorescence (cm⁻¹) in the solvent and in the gas phase, respectively. μ_c is the dipole moment of the complex, assumed to be spherical, situated in a solvent cavity of radius a . This radius is often assumed to be equal to the encounter distance between the monomer components of the exciplex, and a value of 4.5 Å is frequently used.

Plots of $\bar{\nu}_c$ vs. $(f_{(\epsilon)} - f_{(n)})$ or vs. $(f_{(\epsilon)} - 1/2f_{(n)})$ ²³ are linear for many exciplexes, and the slopes give dipole moments for the exciplexes if a value for the encounter distance is assumed. Some exciplex dipole moments obtained in this way are 10 D (anthracene-diethylaniline complex);²³ 11 D (1-naphthonitrile-triethylamine);⁵⁰ 10.8 D (1-naphthonitrile-1,2-dimethylcyclopentene);¹⁰ and 9.2 D (1-naphthonitrile-2,5-dimethyl-2,4-hexadiene).¹⁰ Noting that complete electron transfer would give a dipole moment of 21.6 D, these experimental values of 9-11 D show there is considerable charge-transfer character in the above examples.

An interesting point arises in solvents where the static and high-frequency dielectric constants are equal, i.e., where $\epsilon = n^2$. In such solvents $f_{(\epsilon)} - f_{(n)} = 0$, and in a series of these solvents exciplex fluorescence should show no solvent shift. A study of pyrene-dimethylaniline and anthracene-dimethylaniline exciplexes in

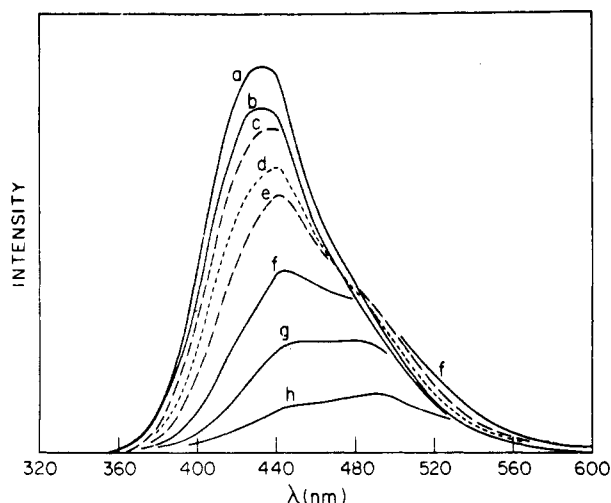
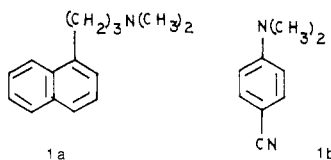

Figure 9. Effect of *N,N*-dimethylformamide on the exciplex fluorescence of **1** in benzene solution. Dimethylformamide concentrations were (a) 0, (c) 0.13 M, and (h) 3.64 M. From ref 52.

aromatic hydrocarbon solvents has been made by Basu.⁵¹ Even though $\epsilon = n^2$ for the solvents used, significant shifts were observed.⁵¹ These were attributed to termolecular complex formation involving the exciplex and a molecule of hydrocarbon solvent (i.e., benzene, *p*-xylene, or mesitylene). The latter have different ionization potentials, and termolecular complexes with different stabilities should be formed. This was consistent with a more detailed study,⁵¹ in which the exciplex fluorescence intensity of the pyrene-dimethylaniline system was measured in *n*-heptane containing different amounts of benzene. An isoemissive point was observed, and the fluorescence maximum appeared at the same frequency as in pure benzene. This indicates that only one new species is formed, which is the same in benzene and in benzene-heptane mixtures.

In earlier work, Chandross and co-workers⁵² found that the singlet excited states of molecules, such as *N,N*-dimethyl-3-(1-naphthyl)propylamine (**1a**) and 4-



(dimethylamino)benzonitrile (**1b**), which can be regarded as "intramolecular" exciplexes, formed 1:1 aggregates with small dipolar molecules like propionitrile, *N,N*-dimethylformamide, and hexamethylphosphoramide.

For example, the internal exciplex (**1a**) is quenched by *N,N*-dimethylformamide in benzene at about $1/10$ of the diffusion-controlled rate, as shown by a typical Stern-Volmer plot. The fluorescence bandshape also changes with added dimethylformamide, as shown in Figure 9. Although no isoemissive point is observed, the data suggest that molecular aggregates of the exciplex of **1a** and dimethylformamide are formed, and these have mainly 1:1 stoichiometry. However, some higher aggregates (more quencher molecules) may also be formed. 4-(Dimethylamino)benzonitrile (**1b**) behaves similarly.⁵²

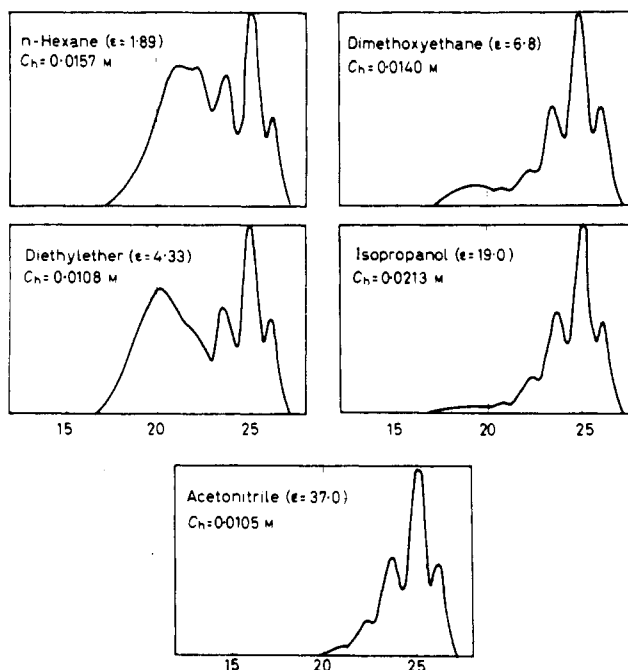
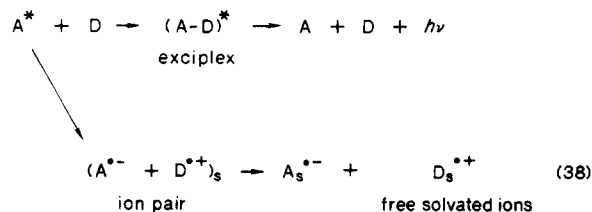

Figure 10. Fluorescence of anthracene quenched by diethylaniline in different solvents. C_q is the diethylaniline concentration required to quench the anthracene fluorescence by 50% in each case. Wavelength (horizontal) scale is in cm^{-1} . From ref 23.

2. Exciplex Decay Processes in Polar Solvents

As the dielectric constant of the solvent is increased, the fluorescence intensity of polar exciplexes generally decreases,^{23,53} and the exciplex lifetime becomes shorter.⁵³ There are specific cases where these trends are not followed, but in these instances solvents at the lower end of the polarity scale are involved. These cases are discussed below.

In very polar solvents, exciplex quenching is always observed, and solvent effects on the anthracene-dimethylaniline system are shown in Figure 10.²³ The exciplex fluorescence (structureless band) is strongly quenched in dimethoxyethane and 2-propanol and is not observed at all in acetonitrile. The anthracene fluorescence is quenched to the same extent (50%) in each solvent. Weller and co-workers proposed that electron transfer leading to ion pairs, and ultimately to free solvated ions, becomes an increasingly important quenching mechanism as the solvent polarity is increased.⁵³ In very polar solvents, electron transfer becomes the major or exclusive pathway for monomer quenching, and since the ion pairs are nonfluorescent, no long-wavelength fluorescence is observed. Equation (38) shows the competing processes:



Radical ions, formed by electron transfer in polar solvents, have been observed directly in several systems. Since these ions can be detected by their characteristic ultraviolet absorption, flash photolysis has proven useful.⁵⁴⁻⁵⁷ Also, the free ions can be detected by

SCHEME II

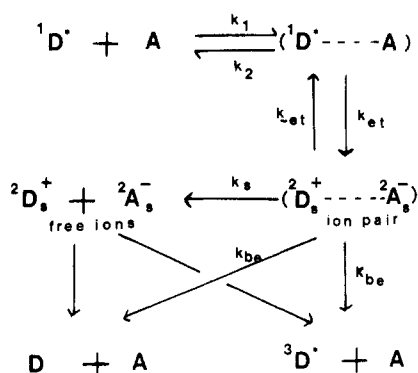

measuring the solution conductivity after a photolysis flash,⁵⁶ and thus can be distinguished from polar exciplexes, which can have similar absorption spectra.

Grellmann et al.^{54,55} have studied the electron-transfer fluorescence quenching of aromatic hydrocarbons, using *p*-dicyanobenzene and tetracyanoethylene as electron acceptors. Hydrocarbons used included anthracene, pyrene, naphthalene, phenanthrene, and several others; the solvent was acetonitrile.

Radical ions were observed on flash photolysis of all the above systems, and kinetics for their decay were determined.^{55,56} These revealed several interesting features. The case of pyrene was complex, the cation being observed even in the absence of quencher (presumably by triplet-triplet annihilation). Also, in the presence of quencher (e.g., *p*-dicyanobenzene), the pyrene cation was formed from both singlet and triplet excited states.⁵⁵ For the other arenes, the radical cations decayed by a combination of first- and second-order processes, indicating that some of the decay involved ion pairs and some occurred via free ions. The principal decay pathway was back electron transfer to give ground-state arene, or triplet-state arene plus ground-state acceptor.^{55,56} These reactions are summarized in Scheme II.

An "encounter complex" is formed by diffusion (rate constants k_1 , k_2), which then undergoes reversible electron transfer giving an ion pair (k_{et}).⁵⁸ The ion pair can dissociate giving free ions (k_s), and back electron transfer (k_{be}) affords ground-state or triplet excited donor molecules. Note that this scheme applies to polar solvents and does not involve exciplex intermediates.

In medium-polarity solvents, the situation is more complex. Conductivity studies have shown that ions are formed as well as fluorescent exciplexes.⁵⁶ The yield of ions from the pyrene-*N,N*-dimethylaniline system was related to the solvent dielectric constant and not to empirical measures of solvent polarity. Time dependence of the photocurrent, observed after a photolysis flash, showed that ions are formed in two processes, perhaps by exciplex dissociation as well as direct quenching of the excited pyrene.^{56,59a} Also, the radiative lifetime of exciplexes is solvent dependent, indicating that the exciplex structure varies with the solvent. In this reviewer's opinion, more extensive work on medium-polarity solvents is required.

We note in passing that electron transfer from an electron donor to an acceptor, as shown in Scheme II, is not the only way of generating radical ions photochemically. For example, radical cations of anisole and 1,4-dimethoxybenzene were observed on flash photolysis

of these ethers in water.^{59b} Also, a number of arenes, including naphthalene, stilbene, fluorene, and diphenylmethane, gave transient absorption spectra on laser flash photolysis at 249 nm in acetonitrile.^{59c} Transient absorptions in the range 600–840 nm were assigned to the radical cations, since the same absorption was obtained on excitation at 350 nm in the presence of chloranil. Transient absorptions in the range 480–550 nm were attributed to the radical cation dimers $Ar_2^{\cdot+}$. A monophotonic ionization giving radical cations and solvated electrons was suggested. Kinetically, the radical cations decayed via a fast, second-order process corresponding to combination of the cations with solvated electrons.

D. Excited-State Electron Transfer: Thermodynamics, Kinetics, and Theoretical Aspects

1. Thermodynamics

In the previous section it was noted that excited-state electron transfer between donor and acceptor molecules occurs in polar solvents. A fairly accurate value for the free energy of electron transfer can be calculated from the oxidation and reduction potentials of the donor and acceptor and the excitation energy of the excited molecule. For ion-pair formation from A^* and D shown in eq 38, the free energy change for electron transfer (ΔG_{et}) is given by eq 39.⁵⁸

$$\Delta G_{et} = 23.06 \{ E1/2(D/D^+) - E1/2(A^-/A) - e_0^2/\epsilon a \} - \Delta E_{0,0} \quad (39)$$

The half-wave potentials ($E1/2$) for oxidation of the donor and reduction of the acceptor are used, with the zero-zero excitation energy of the excited molecule ($\Delta E_{0,0}$). $e_0^2/\epsilon a$ is a Coulombic term giving the stabilization of the ion pair at separation a in solvent of dielectric constant ϵ . Equation 39 gives ΔG_{et} in kilocalories per mole.

The electrostatic term is small (0.06 eV for acetonitrile) and is often neglected for polar solvents. This may not be accurate, since the microscopic dielectric constant for the space between the ions may be smaller than the macroscopic value.⁶⁰

However, in view of the large number of half-wave potentials now available for organic compounds,^{33,34,58,61} inorganic complexes,^{61d,62} and biological molecules,⁶³ there is little doubt that eq 39 is very useful for determining the spontaneity of electron-transfer reactions.

2. Theory and Kinetics

The theory of electron-transfer reactions has been widely discussed in recent years and is usually concerned with the activation energy for the process. Therefore, theory and kinetics are treated together in this section.

The model used in discussing electron transfer was proposed at an early stage by Marcus.⁶⁴ This model uses potential-energy diagrams, such as are shown in Figure 11. These diagrams are extremely useful in discussing electron transfer^{65,66} and other "fast" processes, such as energy transfer.⁶⁷ Such processes occur

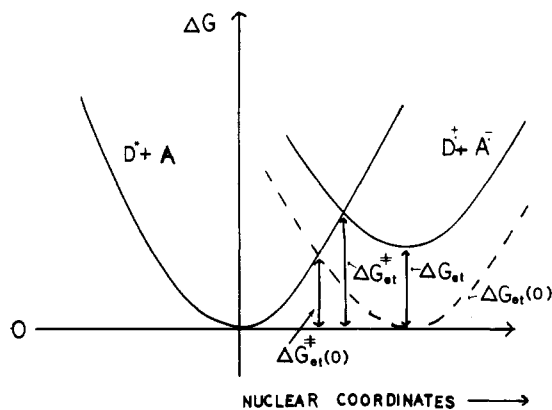
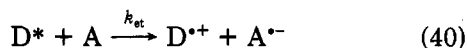

Figure 11. Free energy profile for electron transfer as a function of nuclear coordinates.

on a shorter time scale than nuclear motions and are governed by the Franck–Condon principle.⁶⁵ Thus, before the electron is transferred, the energies of the initial and final states are equalized by distortion from their equilibrium geometries. This distortion involves nuclear motions of reactants and products, including solvent, and results in activation energy for the process.

Figure 11 shows the free energy dependence on nuclear coordinates for the simple electron-transfer reaction given in eq 40. ΔG_{et} is the free energy change for



the reaction, and ΔG_{et}^* is the free energy of activation. Also note that where $\Delta G_{et} = 0$ (dashed curve) there is an activation energy given by $\Delta G_{et}^*(0)$ and that ΔG_{et} can be obtained by using eq 39.

The reaction shown in eq 38 of course results in quenching of the excited state (D^*) according to the Stern–Volmer equation (eq 3). By a kinetic analysis,⁵⁸ the Stern–Volmer constant ($k_{SV}/\tau_{D^*} = k_q$) can be related to the free energy changes in Figure 11. The kinetic scheme shown in eq 41 is usually assumed.⁵⁸

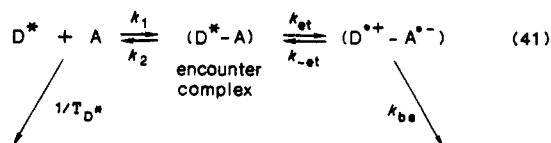

These steps are also shown in Scheme II. An encounter complex is formed by diffusion, which undergoes reversible electron transfer; k_{be} is the sum of all decay processes of the ion pair.

This scheme gives eq 42 for the observed quenching constant (k_q) on application of the steady-state approximation.⁵⁸

$$k_q = \frac{k_1}{1 + \frac{k_1}{\Delta V k_{be}} \left[e^{\frac{\Delta G_{et}^*}{RT}} + e^{\frac{\Delta G_{et}}{RT}} \right]} \quad (42)$$

$\Delta V (=k_1/k_2)$ is called the encounter volume, and ΔG_{et} and ΔG_{et}^* are the free energy difference and activation free energy, respectively, for the electron-transfer step (Figure 11).

Rehm and Weller⁵⁸ found that the results of quenching rate measurements carried out in acetonitrile with a large number of donor–acceptor systems (varying in ΔG_{et} over the range -25 to $+6$ kcal/mol) could be

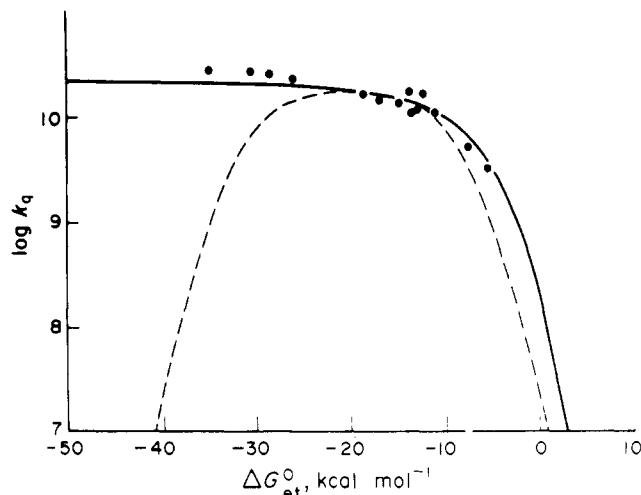

Figure 12. Logarithm of fluorescence quenching constant k_q plotted against ΔG_{et} for the electron-transfer process: (—) calculated by using the Rehm–Weller equation; (---) calculated by using the Marcus equation. Data points are experimentally measured k_q values in ethanol (from ref 63b).

fitted to eq 42 only if ΔG_{et} was assumed to be a continuous function of ΔG_{et}^* . The relation given in eq 43 was found to give a satisfactory fit.

$$\Delta G_{et}^* = [(\Delta G_{et}/2)^2 + (\Delta G_{et}^*(0))^2]^{1/2} + (\Delta G_{et}/2) \quad (43)$$

$\Delta G_{et}^*(0)$ was determined experimentally and is 2.4 kcal/mol for organic molecules in acetonitrile.

Determination of other constants in eq 42 gives eq 44.

$$k_q = \frac{20 \times 10^9 \text{ M}^{-1} \text{ s}^{-1}}{1 + 0.25 \left[e^{\frac{\Delta G_{et}^*}{RT}} + e^{\frac{\Delta G_{et}}{RT}} \right]} \quad (44)$$

When combined with eq 39 and 43, eq 44 can be used to calculate rates of electron-transfer quenching of excited states.

One application of the above kinetic treatment is determination of the quenching mechanism, and a recent example is the quenching of chlorophyll *a* (Chl *a*) fluorescence by a series of quinones.^{63b} Quenching of Chl *a* singlet (1S) by electron acceptors is an important step in photosynthesis,^{63,68} but there has been some difficulty in observing the ions, formed via electron transfer, directly.⁶³

The experimental values of $\log k$ (data points) for quenching of Chl *a* fluorescence in ethanol by a series of quinones are shown in Figure 12, plotted against ΔG_{et} .^{63b} The solid line gives $\log k$ as a function of ΔG_{et} , according to eq 43 and 44. This plot has the same form as that obtained by Rehm and Weller,⁵⁸ and the experimental points are close to the calculated curve. This is reasonable evidence that the quenching involves electron transfer.

The dashed line in Figure 12 is obtained if the theoretically derived eq 45⁶⁴ is used, instead of eq 43, to calculate ΔG_{et}^* .

$$\Delta G_{et}^* = \Delta G_{et}^*(0) [1 + (\Delta G_{et}/4\Delta G_{et}^*(0))]^2 \quad (45)$$

The theoretical equation predicts that a plot of $\log k_q$ vs. ΔG_{et} should be parabolic, as shown by the dashed curve in Figure 12. The decrease in $\log k_q$ as ΔG_{et}

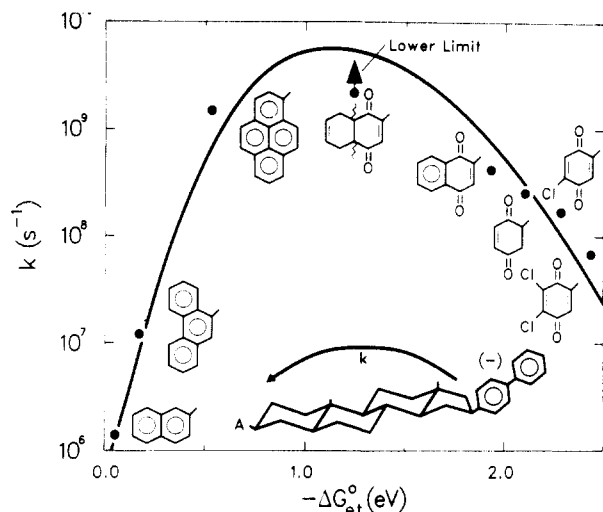

Figure 13. Intramolecular electron-transfer rate constants as a function of free energy change in Me-THF solution at 296 K. Electrons transferred from biphenyl ions to eight different acceptor groups, A. General structure of bifunctional molecules shown in center of figure. From ref 70.

becomes large and negative has not been observed in solution studies, but a leveling off corresponding to diffusion-controlled quenching is obtained.^{58,62,63b,69}

This discrepancy between theory and experiment has been the subject of considerable debate in the literature.^{61d,66,69} One possible reason is that the theory treats nuclear motions classically, but a strictly quantum mechanical treatment should be used.⁶⁹ A second possibility proposed recently⁶⁶ is that in solution the transfer distance may not be the same for all ΔG 's, which is assumed in the above theory.⁶⁴ The variable distance model⁶⁶ proposes that as ΔG_{et} becomes large and negative, the electron is transferred over larger donor-acceptor distances. This model can explain the observed leveling of k_q as ΔG_{et} becomes more negative (Figure 12).

Results that could be relevant to the above discussion have been obtained with bichromophoric molecules.^{70,71} In one study,⁷⁰ an electron-donor group (biphenyl) and a series of eight acceptors were attached to rings A and D of a steroid framework, in which the distance between them was held at 10 Å (Figure 13).

Brief exposure (30 ps) to a high-energy electron beam generated solvated electrons in the solution (Me-THF or isooctane). The latter were captured by the bichromophoric compounds, and the rate of electron transfer (k) from the biphenyl anion to the various acceptors was measured optically. A plot of k vs. ΔG_{et} is shown in Figure 13. This plot has a maximum and is similar to the theoretical (dashed) curve in Figure 12. The steroid-like systems of compounds 2 and 3 have

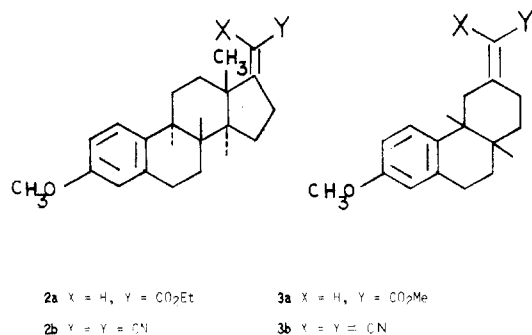

TABLE II. Rates and Quantum Yields for Anthracene Excimers

	monomer lifetime (τ_M), ns	excimer lifetime (τ_E), ns	K_{SV} , M ⁻¹	Φ_{Dim}^{lim}	$\Phi_{f(e)}^{lim}$
anthracene ^a	4	2.5	56	0.16	0.004
9,10-dimethyl-anthracene ^a	12.5	200	95	0.004	0.340

^a Solvent was toluene in all cases.

also been used to study rates of electron transfer as a function of distance, solvent polarity, and donor-acceptor properties, although only two different acceptor groups were used.

The minimum distance between the donor (methoxybenzene) and acceptor (unsaturated ester or dinitrile) was 3.8 and 5.8 Å, respectively. It was found that with the 1,1-dicyanoethylene acceptor, photoinduced electron transfer was extremely fast ($>10^{11}$ s⁻¹) regardless of solvent polarity or donor-acceptor distance. With the weaker acceptor 1-(carboethoxy)ethylene, however, long-range electron transfer occurs much more slowly even in solvents that are sufficiently polar to make ΔG_{et} at least as favorable as for the fast electron transfer which occurs with the stronger acceptor in apolar media. It was concluded that solvent reorganization was responsible for a barrier to long-range electron transfer from the donor to the weaker but not to the stronger acceptor.

In this section, a brief account of the physical aspects of excited-state electron transfer has been given. This field is of considerable importance, and some areas of application are photosynthesis^{63,68} and other biological processes,^{63a} energy-related problems such as photochemical water splitting^{72,73} and photovoltaics,⁷⁴ oxidation and reduction of inorganic complexes,^{62,75} the chemistry of X-ray resist materials,⁷⁶ and electron-exchange-induced chemiluminescence.⁷⁷

The ions and ion pairs formed by electron transfer (Scheme II) can lead to photochemical reactions, some of which are quite general. These are described in section VI.

III. Photoadditions of Aromatic Compounds

A. Dimerization

1. Anthracene and Derivatives

Although the photodimerization of anthracene has been known for a long time,⁷⁸ it is comparatively recently that the scope and mechanism of the reaction have been extensively studied.⁷⁹⁻⁸² Dimerization occurs

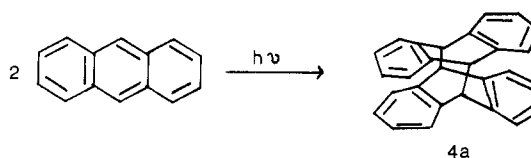

via a singlet excimer, which collapses to photodimer in a $4\pi_s + 4\pi_s$ cycloaddition. The dimer from anthracene is shown in structure 4a.

Since the pyrene excimer, described above, does not photodimerize, the anthracene work is important in providing a link between excimer photophysics and

photochemistry. The kinetic scheme includes the following steps^{81,82} (A = anthracene monomer):

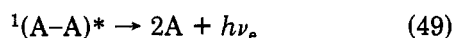
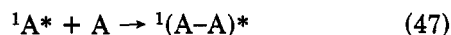

${}^1A^*$ is the singlet excited anthracene, ${}^1(A-A)^*$ is the excimer, and A-A is the stable photodimer. The ratio of excimer fluorescence (reaction 49) to dimerization (reaction 50) depends on substitution of the anthracene monomer.^{81,82} With anthracene and derivatives with negligible steric hindrance to dimerization, e.g., 1- and 2-methylantracene, the dimer is formed efficiently but little, if any, excimer fluorescence is observed.

In cases such as 9,10-dimethylantracene dimer formation is inefficient, but excimer formation occurs, and its fluorescence (reaction 49) occurs with high efficiency.⁸² There are intermediate cases, e.g., 9-alkyl- and 9-acetoxyanthracene, in which dimerization and excimer fluorescence both have reasonable efficiencies.

A quantitative study of reactions and fluorescence from anthracene and 9,10-dimethylantracene excimers has been made,⁸¹⁻⁸³ and some data is shown in Table II.

As shown by the limiting quantum yields for excimer fluorescence ($\Phi_{f(e)}^{lim}$) and dimerization (Φ_{Dim}^{lim}), the anthracene excimer reacts efficiently but fluoresces weakly, while the reverse is true for the 9,10-dimethylantracene excimer. Also, the excimer 9,10-dimethylantracene has the longer lifetime. In the case of anthracene excimer, collapse to dimer is fast, thus the exciplex lifetime is short and fluorescence inefficient. With 9,10-dimethylantracene, the methyl groups hinder dimerization, and fluorescence occurs from the longer lived excimer. Certain polar exciplexes, such as those from 1-naphthonitrile and alkenes,¹⁴ behave similarly, and a consistent picture of excimer and exciplex chemistry has emerged.

A large variety of 9-substituted anthracenes dimerize on irradiation,⁸⁰ giving structures such as 4b-e.

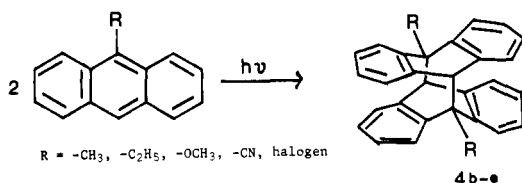

When the substituents are identical, the dimer usually has the head-to-tail regiochemistry, as shown in structure 4. These structures were determined by dipole moments, NMR spectroscopy, and chemical evidence.^{80,81} The structure of the dimer of 9-anthraldehyde has been determined by X-ray analysis.⁸⁴ The regiospecificity has been explained in terms of steric and electrostatic repulsions in the head-to-head arrangement. However, in some cases these repulsions are outweighed by forces of attraction, such as hydrogen bonding. Relatively unstable, head-to-head dimers were

obtained when the substituent (R) was CH₂OCOCH₃ or CH₂NHCOCH₃.⁸¹

Mixed photodimers can be formed on irradiation of 1:1 mixtures of two different anthracene derivatives.^{80,81} For example, 9-cyano- and 9-methoxyanthracene afford dimer 5 in which the two substituents are vicinal (head-to-head).

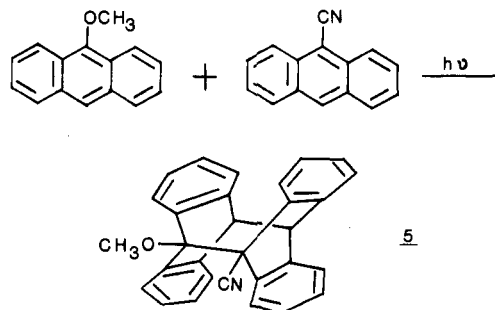

Dimer 5 was the only mixed-dimer formed, and, although unstable, it could be isolated and characterized. Smaller amounts of the dimers of 9-methoxyanthracene and 9-cyanoanthracene were also formed.

2. Naphthalene Derivatives

Although naphthalene shows excimer fluorescence at low temperatures, no photodimers are formed unless the naphthalene units are linked by a saturated chain. Certain 2-substituted naphthalene derivatives do form dimers on irradiation, in particular, 2-alkoxy-naphthalenes^{85,86} and naphthalene-2-carboxylic acid derivatives.^{85,86,88}

For example, 2-methoxynaphthalene affords 4Π_s + 4Π_a addition products, e.g., 6 and 7.

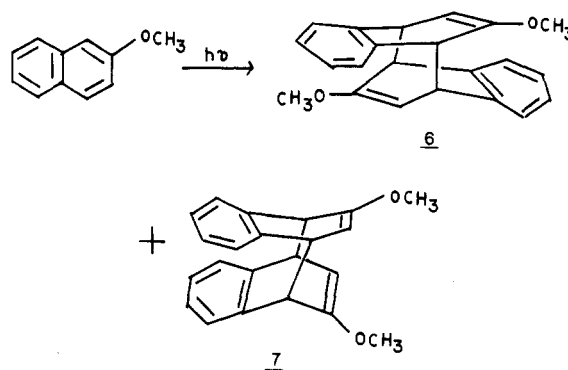

The structure of the photodimer 6 was determined by X-ray crystal structure analysis.⁸⁶ The naphthalenic portions of the molecule are linked in the 1,4-1',4' positions of the substituted rings, in a trans (head-to-tail) configuration. The bond lengths and angles are similar to those of the dimers of anthracene⁸⁷ and 9-anthraldehyde.⁸⁴ This dimer (6) was the first to be isolated, because of its low solubility. The isomeric dimer (7) is more soluble and escaped detection in early work but was isolated and characterized by Sasse and co-workers.^{86a}

Derivatives of naphthalene-2-carboxylic acid also dimerize via bonding between the substituted rings, but four new bonds, rather than two as in 6 and 7, are formed. The photodimer of methyl naphthalene-2-

carboxylate is shown in structure 8a.^{85a,b}

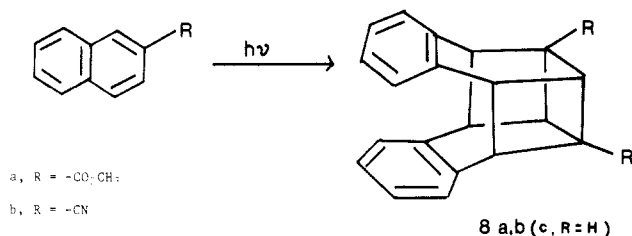

The cage structure for 8a was proposed on the basis of spectral evidence and confirmed by X-ray crystal structure analysis.^{85c} Notably, the regiochemistry of addition is the same as in 6 and 7.

Irradiation of 2-naphthonitrile in cyclohexane gives two dimers, according to recent work.^{88b} One of these gave 8a on methanolysis and is assigned structure 8b. This dimer had been isolated before,^{88a} and had been assigned the cage structure, but with different regiochemistry.

Many naphthalene derivatives have been found not to photodimerize.^{85b} Adducts 6–8 should therefore be useful starting materials for preparing dimers that cannot be prepared directly. One example of this approach is the synthesis of dimers of naphthalene.⁸⁹ Hydrolysis, decarboxylation, and reduction of dimeric ester 8a gave the hydrocarbon dimer 8c. The latter was converted, via the rhodium complex, into the 4π + 4π adduct of naphthalene (parent hydrocarbon corresponding to 7), which gave the syn 2π + 2π dimer of naphthalene via a Cope rearrangement on warming.⁸⁹

3. Formation of Cyclobutane Dimers

Acenaphthylene and Derivatives. Acenaphthylene is an interesting molecule in that, although it fluoresces very weakly, it forms cyclobutane dimers (9 and 10) under a variety of conditions.^{90–92}

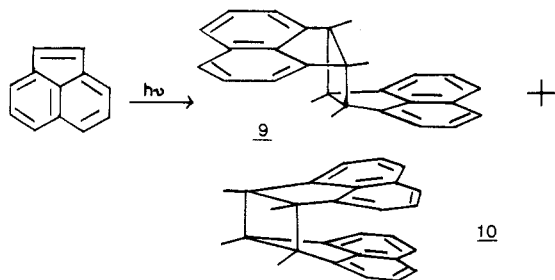

The quantum yield and ratio of trans (anti) isomer (9) to cis (syn) isomer (10) depends on multiplicity, solvent,^{90,91} and alignment of the monomer molecules, e.g., by a liquid crystalline medium.⁹² Some work with substituted acenaphthylenes has also been reported.^{90b,93}

Triplet-sensitized dimerization of acenaphthylene affords the trans dimer 9 as the major product. In light-atom solvents, e.g., cyclohexane, intersystem crossing ($S_1 \rightarrow T_1$) in acenaphthylene is inefficient, ($\Phi_{isc} = 0.02$),⁹¹ and reaction via the singlet gives mainly the cis dimer 10. This is explained by a singlet excimer intermediate that collapses to 10, while ordinary steric effects operate in the triplet dimerization. This seems to be a general rule for many dimerizations (e.g., coumarin,⁹⁴ indene derivatives)⁹⁵ and also for many mixed additions.

Heavy-atom solvents such as ethyl iodide, ethylene

dibromide, and carbon tetrachloride, which enhance intersystem crossing,^{94,96} give larger proportions of 9 on direct irradiation than the light-atom solvents, and the ratios 9/10 have been correlated with spin-orbit coupling parameters.⁹⁶ Thus, the heavy-atom effect is useful in probing reaction multiplicity.^{96,97} The rare gas xenon is sufficiently soluble in organic solvents to be used as a heavy-atom perturber.⁹⁷

Dimerization of acenaphthylene is much more efficient in liquid crystalline media than in isotropic solvents.⁹² The quantum yield in a cholesteric phase is 0.76, while it is 0.012 in toluene at the same concentration (0.02 M) of acenaphthylene. Kinetic analysis showed that the increase in efficiency in the ordered medium was due to an increase in the fraction of collisions leading to reaction and not to an increase in the total number of collisions between the monomer molecules.

Photodimerization of 1-substituted acenaphthylenes, e.g., cyano compound 11, can in principle give four cyclobutane dimers (head-to-head and head-to-tail, with syn and anti stereochemistry for each).^{90b} Irradiation of 11 in ether solution in the presence of oxygen gives

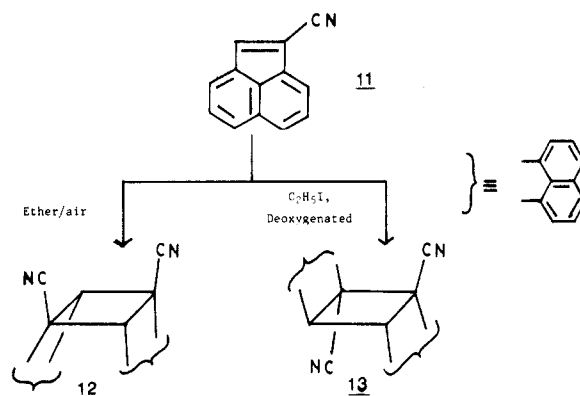

a 96% yield of the syn, head-to-tail dimer 12.⁹³ In deoxygenated ethyl iodide, however, both regiochemistry and stereochemistry are reversed, and a 94% yield of the anti-head-to-head dimer 13 is obtained.

The syn compound 12 results from a singlet complex, in which the regiochemistry is controlled by dipole-dipole repulsions, while the anti isomer 13 is formed from the triplet state. Structure 13 is determined by ordinary steric effects, and stabilization of the 1,4-biradical intermediate by the cyano group. These controlling factors seem to be quite general and appear to operate in the dimerization of many cyclic aromatic compounds.

4. Phenanthrene and Derivatives

Phenanthrene itself does not photodimerize on irradiation under the usual conditions in solution. The photodimer 15 has been made by irradiating the macrocyclic diene 14.⁹⁸

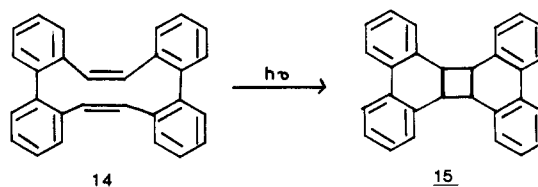

The cyclobutane **15** is reasonably stable, but on thermolysis gives 2 mol of phenanthrene.

Suitably substituted phenanthrenes will dimerize on irradiation. For example, 9-cyanophenanthrene and some of its derivatives afford adducts that are derivatives of **15**.^{99,100} 9-Cyanophenanthrene and its derivatives have been used extensively in mechanistic work.^{37,100}

5. Styrene-Like Systems

A number of molecules are known to give cyclobutane dimers on irradiation, the reactions frequently becoming more efficient and specific when triplet sensitizers are used. These molecules include styrene, indene, coumarin, stilbene, and cinnamic acid and its derivatives, which all have an ethylenic double bond conjugated with an aromatic ring. The sensitized dimerization of indene is typical,^{101,102} the product (**16**) having head-

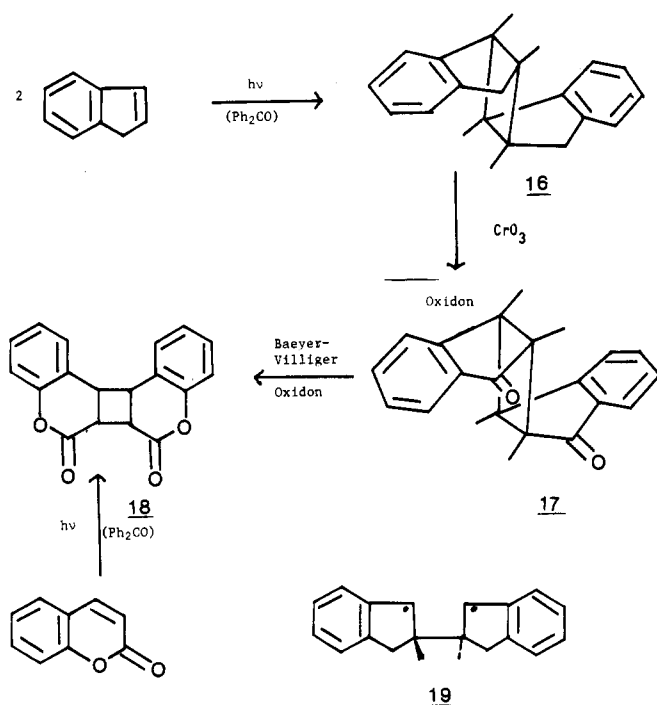

to-head regiochemistry and anti-trans stereochemistry.¹⁰² Similarly, 1,2-dihydronaphthalene affords a dimer with the same regiochemistry and stereochemistry as **16** on sensitized dimerization.¹⁰³

The structure and stereochemistry of dimer **16** were determined by conversion to ketone **17**, followed by Baeyer-Villiger oxidation to the known dimer **18** of coumarin.¹⁰² The latter is formed on sensitized dimerization of coumarin,¹⁰⁴ and since the Baeyer-Villiger oxidation is stereospecific, the conversion of **16** to **18** shows that both dimers have the same geometry.

Triplet additions often lead to head-to-head cycloadducts, such as **16**, where the controlling factor is formation of the most stable biradical, e.g., **19** in the case of indene. No head-to-tail adducts are formed on triplet dimerization of indene, but 17% of the head-to-tail orientation is observed in the dimerization of 1,1-dimethylindene,⁹⁵ presumably a result of steric effects.

Styrene has been reported to form 1,2-diphenylcyclobutane on triplet sensitization.¹⁰⁵ The process is reversible, and the same 1,4-biradical was proposed for

these reactions and for the thermal dimerization.

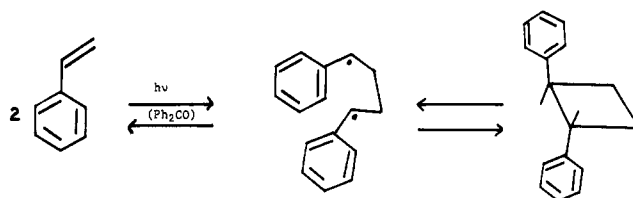

This reaction does not seem to be synthetically useful, however, since a recommended preparation of 1,2-diphenylcyclobutane does not utilize styrene as a starting material.¹⁰⁶

A recent report described the direct photolysis and triplet dimerization of 2-vinylnaphthalene.¹⁰⁷ Direct irradiation gave mainly *cis*-1,2-di(2-naphthyl)cyclobutane (90%) with a minor amount of *trans* isomer (10%). An intermediate singlet excimer was proposed. Benzophenone-sensitized photolysis gave these isomers in the ratio (*cis*:*trans*) of 1:4, which is consistent with the biradical mechanism described above.

Another styrene derivative that undergoes interesting photochemistry is *cis*-1-phenylcyclohexene.¹⁰⁸⁻¹¹⁰ Direct irradiation can yield a variety of products depending on the reaction conditions. For example, cyclobutane and Diels-Alder type adducts, methanol addition products, and compounds resulting from photoreduction have all been observed on irradiation in methanol.¹⁰⁸⁻¹¹⁰

Direct irradiation in neutral methanol at room temperature gives a mixture of the *syn* and *anti* dimers (**20** and **21**) in 58% yield.

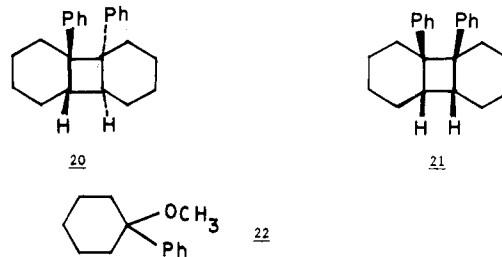

Kinetic analysis strongly suggested that these dimers are formed via the singlet excited state, possibly via an excimer.¹⁰⁹ Only a few percent of methanol addition product **22** was observed in the absence of acid.¹⁰⁹

Irradiation of *cis*-1-phenylcyclohexene in neutral methanol at -75°C produced a different mixture of products. The yields of **20** and **21** decreased, that of ether **22** increased with respect to the room temperature reaction, and a new dimer (**24**) was formed.¹⁰⁹ Aceto-

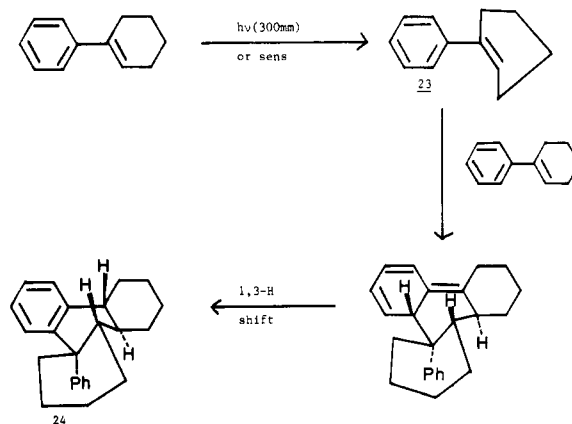

phenone sensitization also produced the latter dimer (24), whose structure was determined by X-ray diffraction.¹⁰⁸ Formation of 24 was proposed to occur via a nonplanar, *trans*-1-phenylcyclohexene (23), for which supporting evidence came from flash photolysis studies.¹⁰⁸ The sequence shown involves addition of the strained, ground-state, *trans* isomer to a second molecule of 1-phenylcyclohexene in a $4\pi + 2\pi$ reaction, followed by a 1,3-hydrogen shift.

In acidic methanol, methoxy compound 22 is the major product, both on direct irradiation and on sensitization.¹⁰⁹ A transient was observed (λ_{\max} 385 nm) whose lifetime depended on the concentration of acid, and this dependence was correlated with quantum yields of product 22 by a kinetic analysis. This is evidence that 22, like dimer 24, is formed via the *trans*-1-phenylcyclohexene.¹¹¹

Formation of these strained, *trans* isomers is of course due to the tendency of ethylenic compounds to twist about the carbon-carbon double bond in the excited state,¹¹² which has long been known to determine product geometries in photoadditions of 2-cyclohexenones.⁸

Although an enormous amount of photochemistry has been carried out by using stilbenes, relatively little systematic work has been done on the dimerization. One report described the dimerization of stilbene and monosubstituted stilbenes in water.¹¹³ Reasonable yields of cyclobutanes were obtained on irradiation of aqueous solutions which were 10^{-4} – 10^{-6} M in the stilbene reactants. No detectable dimerization occurred on similar irradiation of benzene solutions. It was concluded that in water dimerization occurred because of aggregate formation.¹¹³ An earlier report had described the dimerization of stilbenes substituted with electron-donating groups.¹¹⁴ The dimerization apparently was more efficient with these compounds than with stilbene itself and appeared to involve the singlet excited states.¹¹⁴ Most of the stilbenes studied gave two isomeric cyclobutanes, but the precise structures of these could not be determined.

6. Cinnamic Acid and Derivatives

Photochemical reactions of cinnamic acid and its derivatives have been studied under a variety of conditions, including in the crystalline state,^{115,116} as Lewis acid complexes,¹¹⁷ as esters in liquids and glasses,¹¹⁸ as polymer-bound reactants,¹¹⁹ and as lipid-like derivatives that form monolayers and bilayers in water.¹²⁰

trans-Cinnamic acid crystallizes in three crystalline forms. The α -form has the molecules in the crystal lattice arranged head-to-tail, while in the β -form they are arranged head-to-head.¹¹⁵ The intermolecular distance is 3.6 Å in both forms. Irradiation of the α -form gives α -truxillic acid (25), while the β -form gives β -truxinic acid (26).¹¹⁶ However, since the β -form of *trans*-cinnamic acid is thermally unstable, irradiation of crystalline β -nitrophenyl cinnamate is a more practical way of preparing β -truxinic acid.^{115b} The appropriate crystalline form of the *p*-nitrophenyl ester is stable, and base hydrolysis of the resulting (cyclobutane) ester affords β -truxinic acid in good overall yield.^{115b}

A third crystalline form (γ -cinnamic acid) has a larger intermolecular separation (4.7–5.1 Å) and is photo-

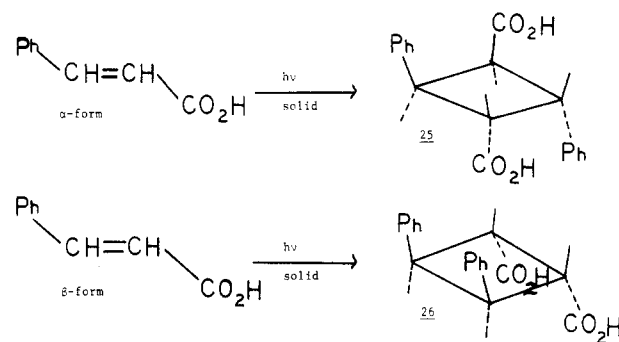

chemically unreactive. Some of the chlorocinnamic acids behave similarly.¹¹⁵

In solution, photodimerization of simple esters of cinnamic acid is inefficient. However, irradiation of neat liquid ethyl cinnamate at room temperature, or of the glass formed at <-80 °C, gives cyclobutanes in high yield.¹¹⁸ Six of the 11 possible cyclobutanes were identified. A head-to-head dimer was the principal component in the liquid, while three isomers in similar proportions were formed in the glass.¹¹⁸ This indicates that the monomer esters are immobilized in the glass with certain configurations.

Lewis acid complexes of cinnamate esters dimerize on irradiation in solution or in the crystalline state.¹¹⁷ Thus, irradiation of *trans*-methyl cinnamate (0.2 M) and BF_3 etherate (0.1 M) in methylene chloride affords a high yield of a mixture of truxinate and truxillate dimers (quantum yield of 0.011). Use of SnCl_4 also gave a mixture, with a different distribution of isomers.¹¹⁷ Thus, complexing favors formation of head-to-tail dimers (truxillates) of the cinnamate esters in solution, vs. the head-to-head isomers, just as in the case of coumarin photodimerization.¹²¹

Irradiation of the 1:1 complex of ethyl cinnamate and BF_3 or of the 2:1 complex of the ester with SnCl_4 gave a high yield of essentially one product, the ester of α -truxillic acid (25). This is consistent with the predictions of a computer model of the stacking of these complexes in the crystal.¹¹⁷

The stereochemistry of cinnamate dimerization can be directed by attaching the cinnamate groups to a polymer that contains cavities of a specified geometry.¹¹⁹ The cavities are formed by making the polymer (styrene-divinylbenzene type) in the presence of a derivative of α -truxillic acid or β - or δ -truxinic acids. Irradiation of cinnamate residues in the cavities of each of these three polymers gives 100% α -truxillic acid, a 1:1 mixture of α -truxillic acid and β -truxinic acid, and a 1:1 mixture of α -truxillic acid and δ -truxinic acid, respectively.¹¹⁹ The fact that δ -truxinic acid (26a) is not ob-

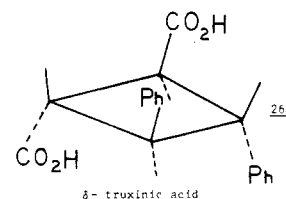

served on irradiation of cinnamic acid or cinnamates under any other conditions is a clear indication of the "template" effect of this polymer.

B. Photoaddition of Aromatic Compounds to Alkene Derivatives (Mixed Additions)

1. Monocyclic Aromatics

Although benzene forms an excimer in solution,¹²² it does not photodimerize. Benzene and its derivatives do, however, undergo a number of important photoaddition reactions with various unsaturated compounds including alkenes, allenes, maleic anhydride, and acrylonitrile. The photochemistry of benzene has been reviewed in detail,¹²³ therefore, only a few selected examples are included here.

Benzene can add to alkenes in three different ways, giving 1,2(ortho)-adducts, 1,3(meta)-adducts,¹²⁴ and 1,4-adducts (routes a, b, and c, respectively). The 1,2-

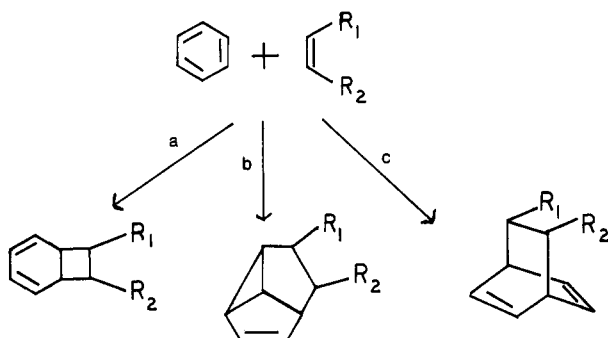

and 1,3-addition modes are the most common, and the latter is currently receiving considerable attention.

The 1,2-cycloaddition of benzene and its derivatives to ethylenic compounds is favored when there is significant donor-acceptor interaction between the two molecules.^{123,124} This rule holds for a large number of examples and is a useful generalization. It suggests the intermediacy of charge-transfer type exciplexes in the $2\pi_s + 2\pi_s$ cycloaddition, which has in fact been dem-

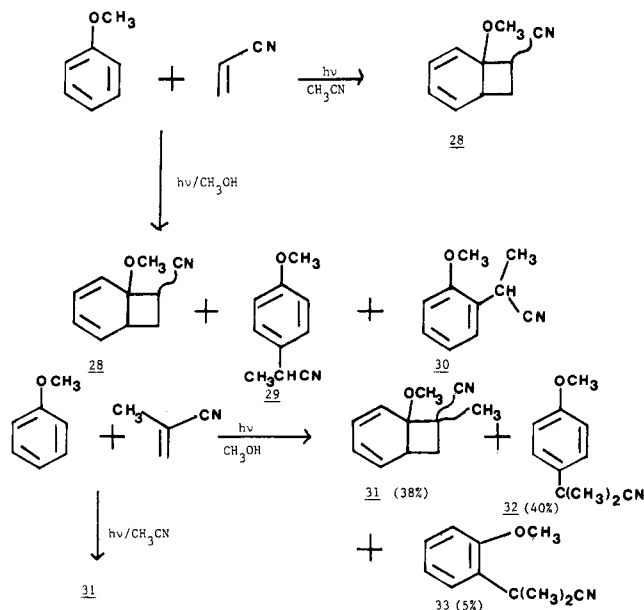
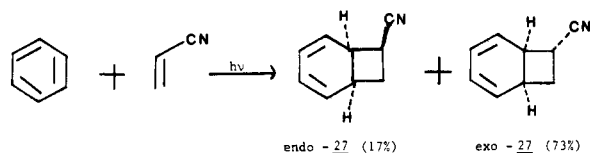

onstrated experimentally for additions of 1-cyanonaphthalene¹⁴ and 9-cyanophenanthrene³⁷ with alkenes.

For example, benzene, toluene, and anisole react with acrylonitrile and α -methylacrylonitrile giving cyclobutanes (ortho addition) as the only cycloadducts, e.g., 27 and 28.¹²⁴⁻¹²⁶ The yields of cycloadduct from benzene and toluene are low, but can be increased by using the zinc chloride complexes of the nitriles.¹²⁷ The reaction of anisole with acrylonitrile is also solvent dependent.

Formation of the substituted compounds with propionitrile (29, 30) or isobutyronitrile (32, 33) substituents only occurs in protic solvents, and the ratio substitution:cycloaddition depends on the electron affinity of the acceptor molecule (the unsaturated nitrile).^{126b} As pointed out by these authors, this is consistent with our interpretation³ of similar reactions of naphthalene and acrylonitrile, which are discussed below.

Electron-donating ethylene derivatives also react with benzene and with many benzenoid compounds having electron-withdrawing substituents. In the case of benzene, ethylenic compounds with ionization potentials less than ~ 8.70 eV give mainly or exclusively 1,2-cycloadducts. Such compounds include 2,3-dihydrofuran,¹²⁴ tetramethylethylene,¹²⁸ and ethyl vinyl ether.¹²⁸ Under the same irradiation conditions, alkenes with ionization potentials between 8.78 and 9.10 eV (e.g., cyclopentene)^{128,129} give 1,3-cycloaddition exclusively. The strained alkene norbornene (IP = 8.95 eV)

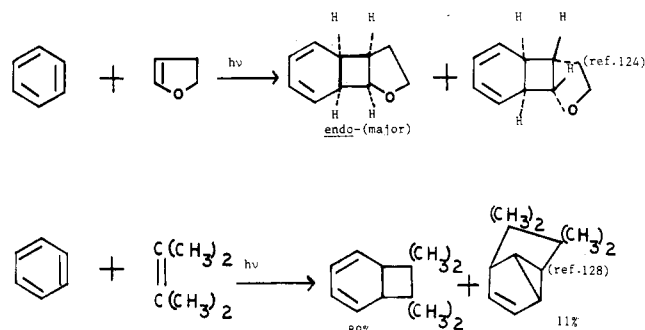

also forms 1,3-adducts with benzene.¹³⁰ Two isomers are formed, with higher quantum yield ($\Phi_{\text{total}} = 0.32$)¹³⁰ than the cyclopentene reaction ($\Phi = 0.16$).¹²⁹ The more strained cyclobutene gives 1,3- and 1,4-addition products on addition to benzene.¹³¹ The reaction is reasonably efficient ($\Phi_{1,3} = 0.1$, $\Phi_{1,4} = 0.01$), but no 1,2-adducts are formed. The 1,3-adducts of cyclic alkenes (e.g., the cyclobutene adduct 34) usually have the endo stereochemistry. It has recently been shown^{132a} that the 1,3-adduct of *tert*-butylbenzene and *cis*-cyclooctene is the endo isomer, in agreement with this rule.

The factors controlling mode of addition, regiochemistry, and stereochemistry of benzene photoadditions are still not completely resolved and discussions continue to appear in the literature.^{132b}

The photoaddition of benzonitrile and alkenes was described some time ago¹³³ but has been reinvestigated more recently.¹³⁴⁻¹³⁶ Products initially isolated were 1,2-cycloadducts of the alkene and the benzene ring.¹³³ For example, benzonitrile and isobutylene give cyclobutane 35 on irradiation in hexane.¹³⁴

This type of adduct represents the only mode of addition for alkenes with high ionization potentials (> 8.80 eV). With better electron-donating alkenes (IP < 8.80

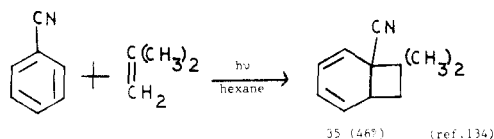
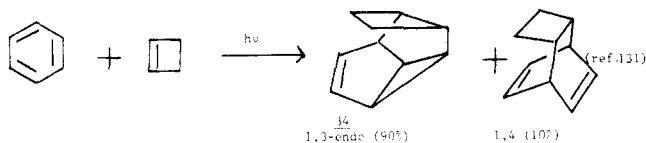

eV), the cyclobutanes are minor products, while 1-azetines, 2-azabutadienes, and their hydrolysis products are isolated.^{134,135} These are formed by addition to the nitrile group. The case of tetramethylethylene is typical:¹³⁴

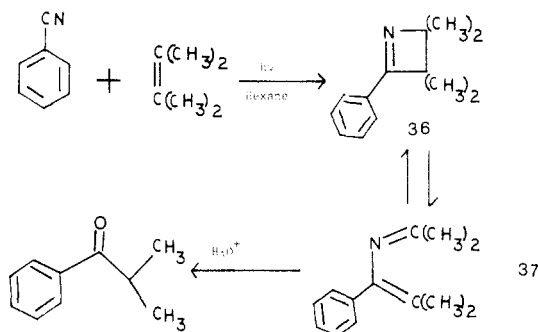

The naphthonitriles behave similarly;¹³⁴⁻¹³⁶ 1-naphthonitrile and 1,2-dimethylcyclopentene, on irradiation in hexane, give two isomeric cyclobutanes ($\Phi_{\text{lim}} = 0.12$) together with a 1-azetine ($\Phi_{\text{lim}} = 0.10$).^{136b} However, many reported ratios of cyclobutane:1-azetine products refer to preparative-scale irradiations. These ratios should be interpreted with caution. Since the cyclobutanes are photochemically labile and the 1-azetines relatively stable, the ratio of products can change with irradiation time. The fraction of azetine is also solvent dependent and is lower in the more polar solvents. Benzene is significantly more polar than hexane in its effect, which is important in our kinetic work employing benzene as solvent.

Addition of alkenes to benzene in the 1,4-mode is relatively rare. Examples include cyclobutene (described above) and allenes. The latter are the only ethylene derivatives known for which 1,4-addition is preferred.^{123,137} Benzene and allene give 1,3- and 1,4-adducts 38 and 39 in the ratio 1:2.¹³⁷

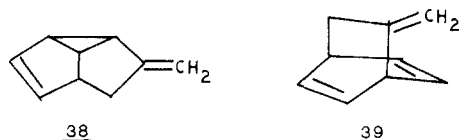

Photoaddition of hexafluorobenzene and cycloalkenes, dienes, or acetylenes¹³⁸ gives 2 + 2 cycloadducts initially, which often undergo secondary reactions. For example, reaction with 1-phenyl-2-*tert*-butylacetylene by irradiating at 254 nm yields 86% cyclobutene 40.^{138a}

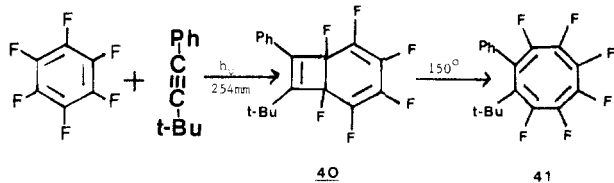

On heating to 150 °C, 40 is transformed into the cyclooctatetraene derivative 41.

Similar reactions occurred with 1-phenyl-2-methylacetylene, but with phenylacetylene the cyclobutene was unstable and only cyclooctatetraenes were isolated.^{138a}

Reaction of hexafluorobenzene with indene,^{138a} 1,2-dihydronaphthalene,^{138a} or norbornadiene gives stable cyclobutane adducts with syn stereochemistry. The norbornadiene adduct is also mainly *exo*.^{138b}

2. Mechanistic Aspects of the Addition of Benzene and Ethenic Compounds

The 1,2-, 1,3-, and 1,4-modes of addition to benzene have been discussed in terms of orbital symmetry and symmetries of the various possible benzene excited states.¹²³ The 1,2- and 1,4-additions can be regarded as $2\Pi_s + 2\Pi_s$ and $4\Pi_s + 2\Pi_s$ additions, respectively. Both of these have ample precedent in the reactions of other unsaturated compounds. Notably, the regiochemistry of addition of substituted ethylenes to monosubstituted benzenes (e.g., formation of 28 and 31) is consistent with PMO theory, which has been applied to photoadditions of stilbene¹³⁹ and phenanthrenes.¹⁴⁰

1,3-Addition to the benzene ring is believed to be related to formation of fulvene and benzvalene,^{123,141,142} and a common intermediate, a biradical called "prefulvene" (42) is sometimes proposed. Apparently

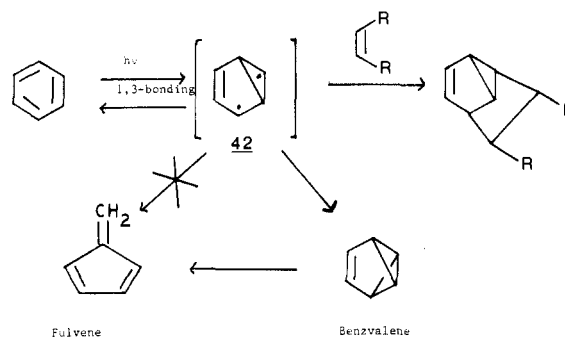

fulvene is not a primary photoproduct but is formed by catalyzed rearrangement of benzvalene.¹⁴²

Although some of the 1,3-adducts may form via this intermediate, quantum yield data have shown that, in the addition of toluene and cyclopentene and of *p*-xylene and cyclobutene, direct addition to the arene S_1 also occurs.¹³¹ This is consistent with orbital symmetry predictions. Application of the Huckel-Mobius rules^{143,144} shows that the 1,3-addition of benzene and ethylene is excited state allowed.

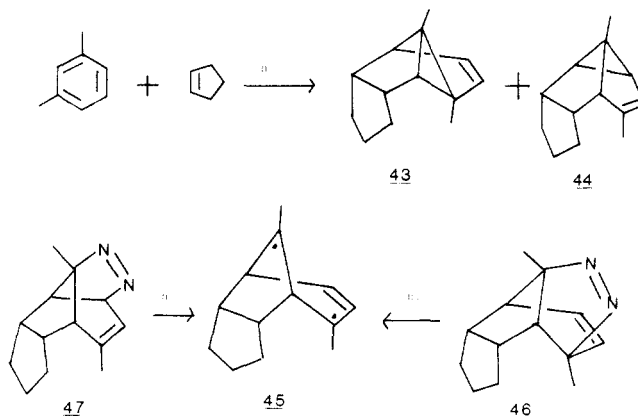

Recent work, however, has focused on possible biradical or zwitterionic intermediates in 1,3-additions.¹⁴⁵ Irradiation of *m*-xylene and cyclopentene gave a 1:1 mixture of adducts 43 and 44.

Intermediacy of biradical 45 was probed by independent generation from azo compounds 46 and 47. Similar experiments were done for the adducts of *o*-xylene and cyclopentene. The ratios of products (43, 44) were similar to those obtained in the photoadditions, and this was taken as evidence supporting the biradical mechanism in the latter reactions.^{145a,b} However, with one exception, all the ratios were in the range 1:1 to 1:1.33, and it is possible that a concerted photoaddition has the same selectivity as closure of biradical 45.

Two groups^{145c,146} have studied the meta addition of arenes, anisole, and benzonitrile to dioxoles and to vinylene carbonate. For example, benzene and dioxoles (48a,b) give the ortho adduct 49 and the exo-meta adduct 50. Significant amounts of exo isomers (50) are only formed when the benzenoid reactant is electron donating, e.g., with arenes or with anisole.^{145c,146} Benzonitrile and trifluoromethylbenzene afford only endo adducts with vinylene carbonate.^{145c} Also, the substituent position in the meta adducts depends on whether it is electron donating or electron withdrawing. On the basis of these observations, the investigators proposed that a polar intermediate, i.e., an analogue of 45 with charge separation, was involved in the meta additions.^{145c}

3. Exciplexes and Benzene Photoadditions

A recent study has attempted to relate exciplex photophysics to photoaddition reactions of the benzene ring.¹⁴⁶ Fluorescent exciplexes are formed from ¹S benzene or toluene and 1,3-dioxoles, and the latter also add to the arenes, forming 1,2- and 1,3-addition products,¹⁴⁶ such as 49 and 50.

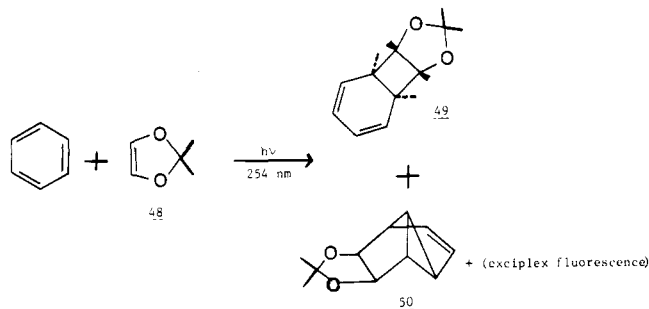

Although both adducts 49 and 50 are formed from benzene ¹S, it was shown that only the 1,3-adduct was formed via a quenchable exciplex. Dilution plots for formation of 49 and 50 were obtained with and without added triethylamine. In both cases, the slope depended on whether the amine was present or not. Since the amine quenches benzene ¹S, this is understandable because K_{SV} appears in the slope (eq 4). However, the intercept in the dilution plot for meta addition was larger with amine present, while in the case of ortho addition, the intercept was unchanged. This shows that a quenchable species, other than benzene ¹S, i.e., exciplex, is involved in meta addition, but that ortho addition proceeds directly from benzene ¹S.

Interestingly, the exciplex appears to be nonpolar,

since ortho addition is favored by dioxoles with lower ionization potentials and by polar solvents relative to meta addition (exciplex pathway).

Also, collapse of the exciplex to meta adduct apparently requires a second molecule of dioxole. Stern-Volmer constants calculated from eq 4 are smaller than the slopes of fluorescence-quenching plots. This discrepancy has been observed before, but no satisfactory explanation had been proposed. A kinetic analysis based on Scheme I requires K_{SV} 's from fluorescence and product quantum yields to be the same. Inclusion of reaction 51 in the kinetics for meta addition accounted for the observed K_{SV} 's.

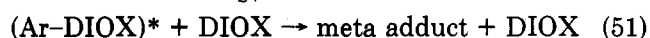

4. Addition of Ethylenic Compounds to Naphthalenes

Benzene and naphthalene are quite different in their photochemical behavior. Although Dewar naphthalene¹⁴⁷ (51) and naphthvalene¹⁴⁸ (52) are known, they are not formed on irradiation of naphthalene.



With the exception of some *tert*-butyl derivatives,¹⁴⁹ simple naphthalenes do not photorearrange. Also, the 1,3-additions of alkenes, so important in benzene photochemistry, are seldom observed with naphthalene, and the 1,2- and 1,4-modes are preferred.

The latter reactions are very sensitive to the alkene structure, and some well-known reactions of other arenes, such as the additions of maleic anhydride, occur very inefficiently with naphthalene. The nitrile substituent, either in the naphthalene nucleus or on the ethylenic reactant, assists photoaddition in many cases.

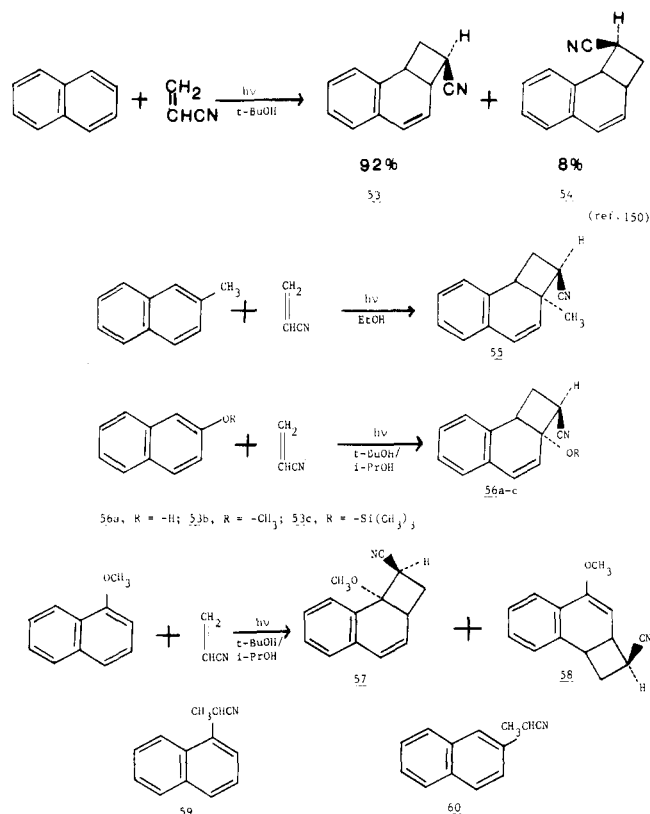

Naphthalene and certain alkoxy and alkyl derivatives react with acrylonitrile on irradiation, giving cyclobutane adducts.¹⁵⁰⁻¹⁵² Examples are shown below. Products (53-63) of the above reactions can be isolated readily, and some of them can be converted into other structures by ring-opening reactions.¹⁵² They are, therefore, of synthetic utility.¹⁵³

The reaction of naphthalene and acrylonitrile is solvent dependent,³ and in the more polar, protic solvents significant amounts of substituted naphthalenes (59 and 60) accompany cyclobutane adducts 53 and 54. The fraction of substituted naphthalenes ranges from <1% (*tert*-butyl alcohol) to 95% (formic acid).

A similar solvent effect has since been observed for other addition reactions, e.g., anisole and acrylonitrile.¹²⁶

The reaction of naphthalene and acrylonitrile involves the naphthalene singlet excited state (¹S), but no exciplex fluorescence is observed. However, addition in deuterated alcohol (CH₃OD) gives substitution products 59 and 60 with a deuterium label in the methyl groups. The simultaneously formed cyclobutanes contain no deuterium. Thus, a nonfluorescent intermediate is being intercepted by solvent to give 59 and 60. This intermediate could be an ion pair or a nonfluorescent exciplex, either of which could be consistent with the observed solvent effects on the ratios of products.³ Fluorescence-quenching studies indicate that the initial quenching of naphthalene ¹S involves exciplex formation rather than electron transfer.³²

Solvent polarity is not the only factor influencing these reactions. For example, no significant addition of naphthalene and acrylonitrile occurs on irradiation in acetonitrile, but the additions of 2-methoxynaphthalene and anisole¹²⁶ occur with about the same efficiencies in acetonitrile and in alcohol. The solvent molecule (alcohol) apparently affects the exciplex decay process, perhaps by forming a termolecular species.^{51,52}

Additions also occur on irradiation of naphthonitriles and electron-rich alkenes, such as tetraalkylethylenes, vinyl ethers, and furans. As noted above, exciplex fluorescence is observed from 1-naphthonitrile and alkylethylenes in nonpolar solvents,¹⁰⁻¹² but not from the vinyl ethers or furans nor from 2-naphthonitrile or any alkenes so far investigated (see, however, ref 154). The products (61-73) of some of these additions are shown in the following examples.

The actual distribution of products obtained can be very dependent on the wavelength of irradiation, extent of conversion, and precise structures of the reactants. For example, the amount of azetine (62) is greater with 1,2-dimethylcyclopentene than with tetramethylethylene^{6,136} and also when hexane, rather than benzene, is used as the reaction medium. Also, 2-methyl-1-naphthonitrile gives the expected cyclobutane (63a), together with an ene-type product (64). The quantum yields are low ($\Phi_{lim} = 0.02$);¹⁴ the products are formed in about equal amounts initially, but 64 is obtained at long irradiation times since it is photostable. Formation of 64 could involve a "photo-ene" reaction, which has been observed before in benzene chemistry.¹⁵⁹

Irradiation of 1-naphthonitrile and vinyl ethers gives epimeric cyclobutanes 65a,b, 66a,b, and 67a,b.^{155,156} When *cis* and *trans*-phenoxypropenes 66 and 67 were used, the stereochemistry of the ethylenic bond was retained in the cyclobutane adducts.¹⁵⁶ In the major adducts, 65a-67a, the alkoxy or phenoxy groups have

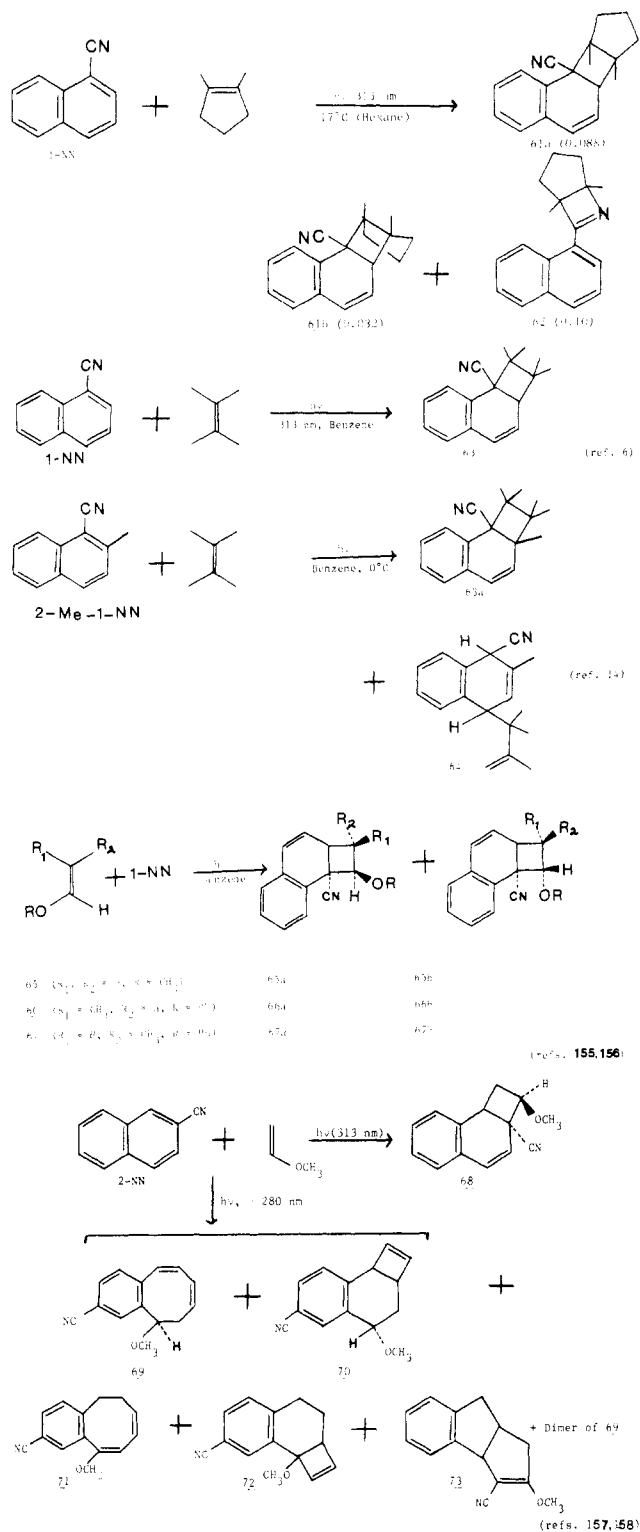

the endo configuration, which seems to be a general rule for these singlet additions.⁸

Photoaddition of 2-naphthonitrile (2-NN) and methyl vinyl ether gives a complex mixture of products. Irradiation at 313 nm affords mainly the cyclobutane 68, but with light of shorter wavelengths (Hg arc, Pyrex filtered) additional products are formed.^{157,158} The latter include cyclooctadienes 69 and 71, cyclobutenes 70 and 72, and methoxycyclopentene 73. A dimer of 69 was also reported by both groups who studied this reaction.^{157,158} Although mechanistic details of this reaction have not been determined, it is likely that

products 69–73 predominate with shorter wavelength light because they are more stable to irradiation than cyclobutane 68. The cyclobutenes and the dimer are undoubtedly formed by secondary photolysis of cyclooctadienes 69 and 71.

Photoaddition of 1-NN and furan affords $4\Pi_s + 4\Pi_s$ adduct 74,^{160,161} reminiscent of the dimers of anthracene and naphthalene derivatives.^{81–87} The structure 74 is

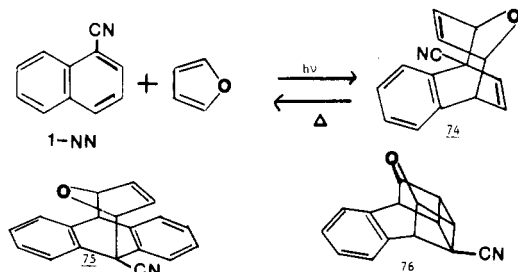

called the “endo” isomer by the authors^{160,161} and was confirmed by X-ray crystal structure analysis.¹⁶¹ A negative temperature dependence for the quantum yield of addition was observed, implicating an exciplex intermediate.^{162a} Irradiation of 9-cyanoanthracene and furan also gives $4\Pi_s + 4\Pi_s$ adduct 75,¹⁶³ while addition of 2-naphthonitrile and furan affords cage-type adduct 76.^{162b} Similar reactions of methyl-substituted furans were observed, but thiophene and *N*-methylpyrrole afforded no cycloaddition products. The work has been reviewed.¹⁵⁴

5. Naphthalene and Acetylene Derivatives

Naphthalene adds to diphenylacetylene on irradiation, giving the cage structure 77.^{164–166}

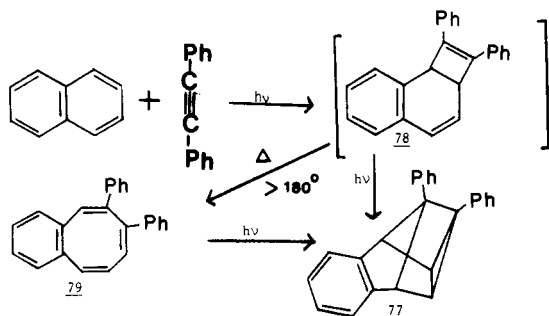

The structure 77 is based on X-ray crystal structure analysis,¹⁶⁵ which showed the earlier structure assignment to be correct.^{164,166} Cyclobutene 78 has been isolated and apparently is an intermediate in the formation of 77.¹⁶⁴ On the thermolysis, 78 yields the cyclooctatetraene 79, which gives the cage compound on irradiation.¹⁶⁴ Cage structures are also formed from methyl-¹⁶⁶ and methoxy-substituted naphthalenes^{167,168a} and from some heterocyclic acetylenes, e.g., phenylpyridylacetylenes.^{168b} These reactions are singlet processes, since they are quenched by oxygen and inhibited by benzophenone.¹⁶⁴

Formation of 1:1 adducts occurs on irradiation of naphthalene and dimethyl acetylenedicarboxylate.¹⁶⁹ The products isolated depend on the reaction conditions, but the primary products have been assigned as the $4\Pi_s + 4\Pi_s$ adduct (80), a substituted naphthalene derivative (81), and a product of formal 1,3-cycloaddition (82). The yield of 80 is low, but it undergoes secondary photolysis to the cyclooctatetraene derivative

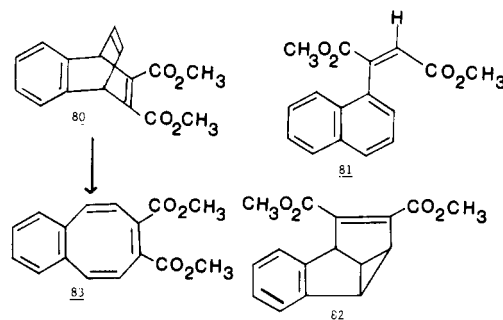

83. These reactions have not been studied in mechanistic detail, but it has been suggested recently that 82 could be formed via 1,2-addition, followed by a di- π -methane rearrangement of the cyclobutene 84, rather than by direct 1,3-addition.¹⁷⁰

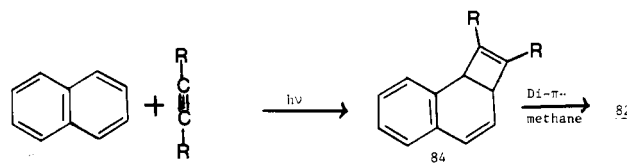

6. Carbonyl Compounds. 1,2- and 1,4-Additions

The above addition of naphthalene and acetylenedicarboxylates is one of the few naphthalene additions involving carbonyl compounds. Scharf and co-workers¹⁷¹ have studied the additions of dichlorovinylene carbonate to naphthalene and to benzene. In both cases, 1,2- and 1,4-adducts are formed, which is consistent with the general rule that these modes of addition are favored over the 1,3-mode in cases where there is significant charge transfer between the reactants.¹²³ The naphthalene adducts are shown below (85, 86).

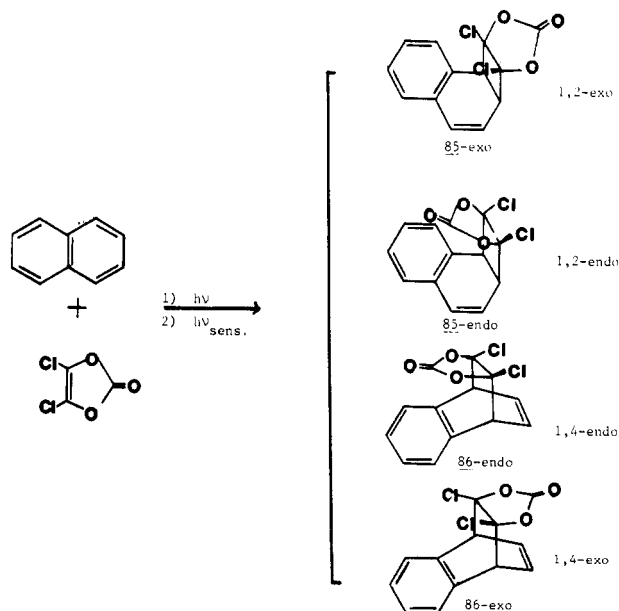

This addition occurs both on direct and on sensitized irradiation. However, it was shown that the former involves ¹S naphthalene and ground-state carbonate, while in the latter, ¹T carbonate adds to ground-state naphthalene.¹⁷¹

Some chemistry of the adducts was described. These

1,2-adducts rearranged to the 1,4-isomers on sensitized irradiation, while on direct irradiation the cyclobutane ring is cleaved and naphthalene is formed. The initial 1,2-adduct of benzene and dichlorovinylene carbonate was trapped with tetracyanoethylene.¹⁷¹

Recently, some additions of carbonyl-substituted naphthalenes (1-naphthaldehyde and 1-acetonaphthone) with "captodative" compounds,¹⁷² such as the morpholinotrile (87), have been described.¹⁷³ These

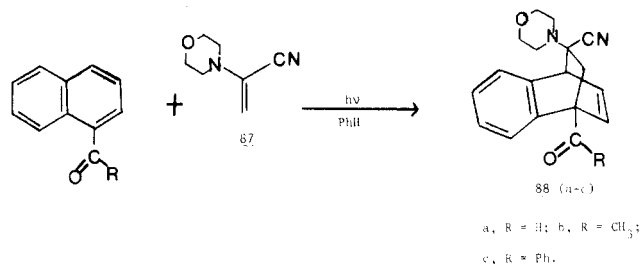

additions occur in the substituted naphthalene ring and are almost exclusively 1,4. Structure 88b is based on X-ray crystal structure analysis,¹⁷³ and the observed regiochemistry apparently rules out significant biradical or zwitterionic character in the transition state for addition. Limiting quantum yields for these additions are of the order 10⁻².

Visible irradiation of naphthalene and *N*-methyl-1,2,4-triazoline-3,5-dione also gives mainly 1,4-addition.¹⁷⁴ The 1,4-adduct can be converted into "diazabenzosemibullvalene", which was used to generate the "benzoprefulvene" biradical by thermal and photochemical loss of nitrogen.¹⁷⁴

7. Addition of Benzene, Naphthalene, and Anthracene to Dienes and Trienes

A number of reactions have been described in which aromatic hydrocarbons, particularly benzene, naphthalene, and anthracene, add to 1,3-dienes.^{175-179,183,184} Some reactions with trienes have also been reported.^{180,181} The diene additions are generally of the 1,2- or 1,4-modes including 2Π_s + 2Π_s, 2Π_s + 4Π_s, and 4Π_s

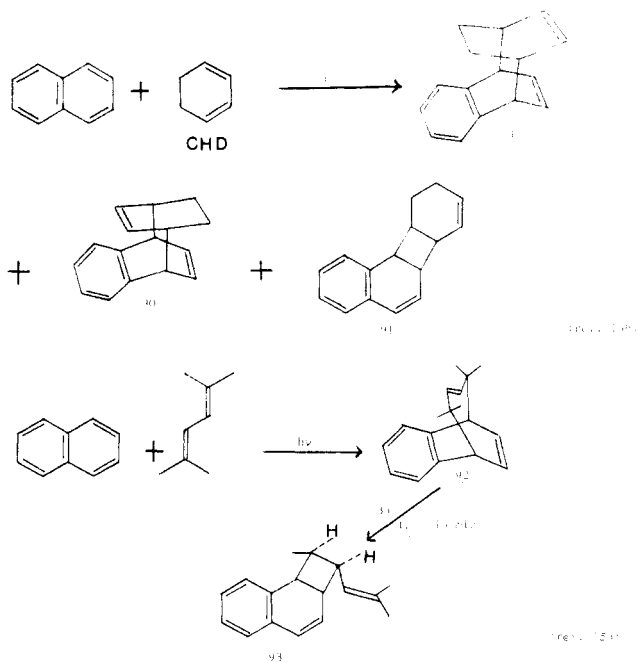

+ 4Π_s. The 1,3 or meta addition is only observed with benzene.¹⁸² The examples given below (89-104) are

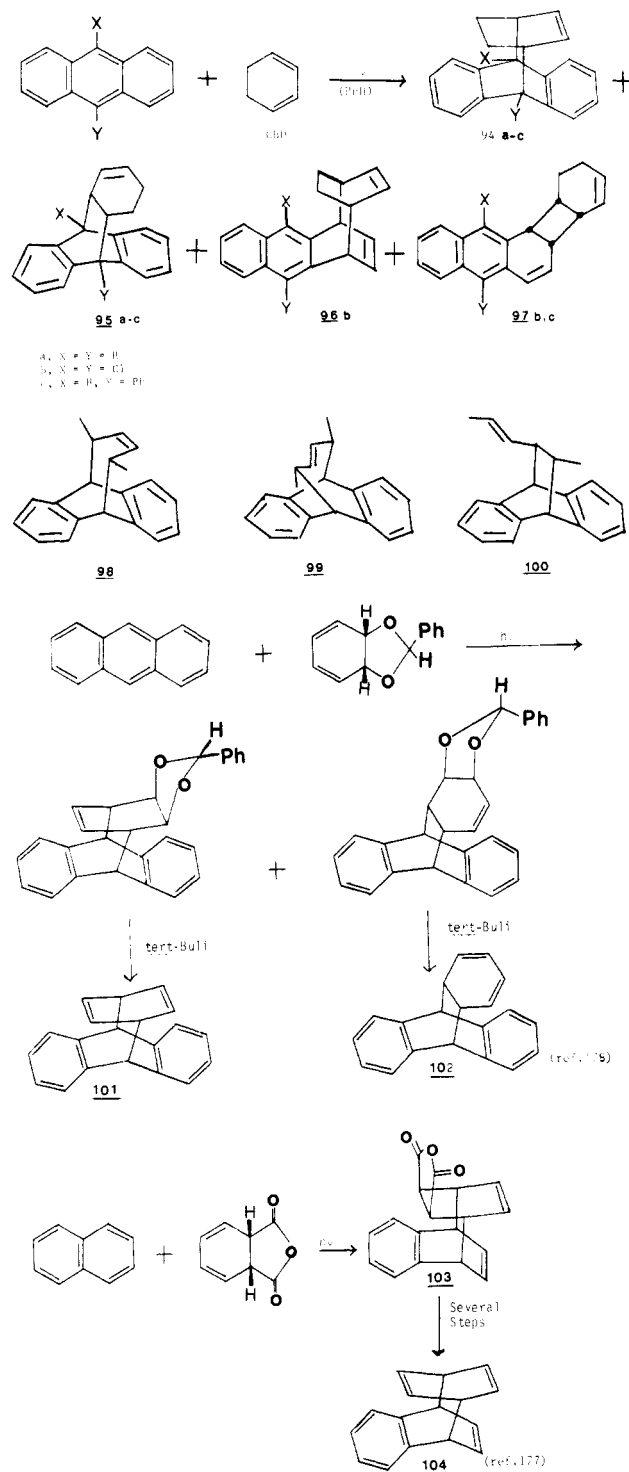

from recent literature, since there are reviews of earlier work.^{175,179} Also, the additions of 9-phenyl-¹⁸³ and 9,10-dichloroanthracene¹⁸⁵ with 1,3-dienes are included for comparison with anthracene.

With naphthalene and 1,3-dienes, the major products are derived from 4Π_s + 4Π_s additions, e.g., 89, 90, and 92. Adduct 92 is interesting in that the strained trans double bond shows that the ground-state geometry of the diene is retained in the adduct. This strain facilitates rearrangement of 92 to the cyclobutane isomer 93 via a 3,3-sigmatropic shift.¹⁷⁶

With anthracenes, the symmetry-allowed 4Π_s + 4Π_s addition is usually preferred, but other modes of ad-

dition can be significant in certain cases. Thus, anthracene and cyclohexa-1,3-diene (CHD) form **94a** on irradiation in benzene, but in the presence of methyl iodide the $4\Pi_s + 2\Pi_s$ adduct **95a** becomes the major product.¹⁷⁵ Acyclic 1,3-dienes behave similarly,¹⁸⁴ and a triplet pathway has been proposed for formation of **95** and **100**.

The trans alkene double bond in adducts such as **99** is reactive and can add a second anthracene molecule via Diels-Alder addition.^{183,184} This results in enhanced anthracene losses in the irradiation, which had previously been attributed to anthracene dimerization.

Additions to the terminal ring in some anthracenes can occur, and 9,10-dichloroanthracene and CHD form substantial amounts of **96b** and **97b**.¹⁸⁵

These diene additions have been used to prepare mixed adducts of anthracene and benzene (**101** and **102**)¹⁷⁸ and naphthalene and benzene¹⁷⁷ (**104**), which cannot be obtained by photoaddition of the hydrocarbon themselves. The synthetic schemes^{177,178} for **101**, **102**, and **104** are shown above.¹⁷⁸

Interestingly, furan, which is diene-like in its ground-state reactions, also gives $4\Pi_s + 4\Pi_s$ photoadducts with 1-naphthonitrile^{160,161} and with 9-cyanoanthracene.¹⁶³ Some additions of 1,3-dienes with higher polycyclic arenes have been described and were interpreted by using orbital symmetry.¹⁷⁹

C. Mixed Photoadditions of Acenaphthylene, Phenanthrenes, Stilbenes, and Styrene Derivatives

This section describes mixed additions of aromatic compounds containing an "ethylene like" double bond, such as the 7,8-bond of acenaphthylene or the 2,3-bond of indene. These bonds have higher bond orders than

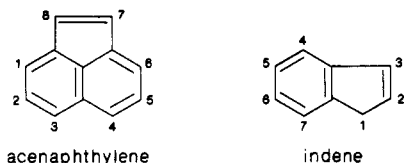

the ring bonds of benzene or naphthalene, and a number of mixed additions occur at these positions. The additions differ from anthracene or naphthalene reactions in that the triplet state is frequently involved. Also, some of the singlet exciplexes from phenanthrenes and stilbenes are fluorescent and have proved useful in mechanistic work.^{37,38}

1. Acenaphthylene

One objective in addition studies of this compound has been conversion of the adducts to pleiadienes, **106**.¹⁸⁶

Acenaphthylene reacts with maleic anhydride and some substituted maleic anhydrides, in halogenated solvents, to form cyclobutane derivatives **107** and **108**. Some of the adducts prepared are shown below.¹⁸⁶

These additions are apparently triplet processes, since significant yields of **107a** and **108a** are only obtained in the presence of heavy-atom solvents such as dichloro- and dibromomethane and methyl iodide.¹⁸⁶ In dioxane

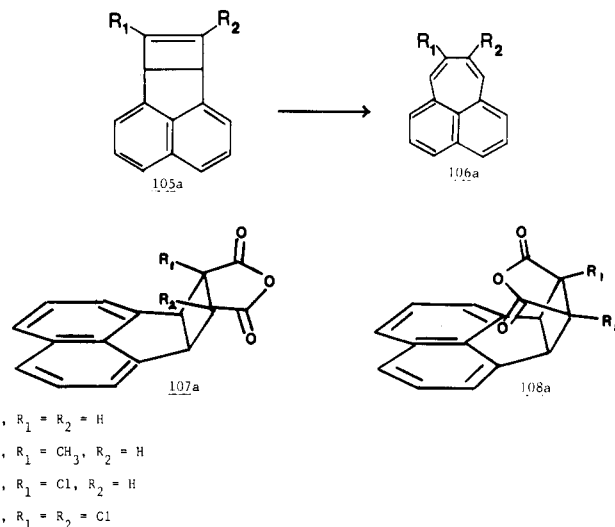

or acetonitrile, only acenaphthylene dimers were reported, and the conversions were low. The mixed additions did occur, however, when benzophenone or benzil were used as sensitizers. The cyclobutenes, **105**, formed by bisdecarboxylation of the diacids, afforded pleiadienes **106** on thermolysis, the parent pleiadene being formed in 50% yield from **105a** ($R_1 = R_2 = H$).

Photoaddition of acenaphthylene and acrylonitrile also exhibits a solvent dependence.¹⁸⁷ The reaction is more rapid in halogenated solvents than in cyclohexane or acetonitrile, and the ratio of stereoisomers **109** and **110** varies with solvent, but the variation is not large.¹⁸⁷

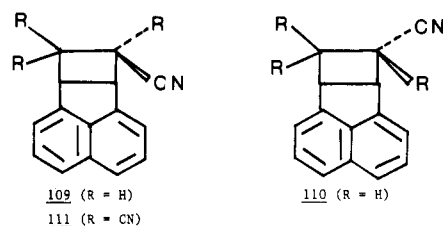

Adducts **109** and **110** have been used as synthetic intermediates.¹⁸⁸ The nitrile substituents were transformed, via the carboxylic acids, into the exo and endo alcohols. Stereochemistry was established by X-ray crystal structure analysis. The mesylate of the endo alcohol gave pleiadene **106a** ($R_1 = R_2 = H$) on solvolysis in acetic acid.¹⁸⁸

Photocycloaddition of acenaphthylene and tetracyanoethylene in dichloromethane affords cyclobutane **111** as the only product, albeit in low yield.¹⁸⁹ The reaction was assigned as a singlet process, involving acenaphthylene 1S . Oxygen or ferrocene had negligible effect on the reaction rate, and the addition did not occur on irradiation of the charge-transfer band ($\lambda_{max} = 550 \text{ nm}$).¹⁸⁹

2. Indene

Several mixed additions of this styrene derivative have been described. The triplet additions resemble those of acenaphthylene. Acetophenone-sensitized addition of indene and acrylonitrile gives the epimeric nitriles **112** and **113**.¹⁹⁰

The only other products are dimers of indene, which are not observed at high (1.0 M) acrylonitrile concentrations. The regiochemistry of **112** and **113** is predicted

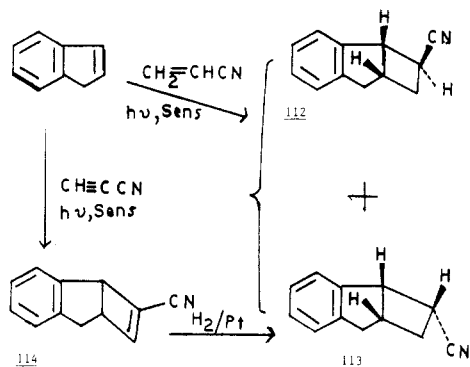

by the "most stable biradical" rule and was confirmed by chemical degradation.¹⁹¹ Hydrogenation of the cyanoacetylene adduct 114 gave the endo adduct (113) in quantitative yield.¹⁹¹

Direct irradiation of indene and acrylonitrile gives a different type of product (115); the mixture of cyclobutanes constitutes only 20% of the reaction mixture.

The treatment of the reaction mixture with mild base (tertiary amine) isomerizes 115a to 115b, while stronger base (e.g., alumina) gives the cinnamitrile derivative 116. The propionitrile derivatives (115a,b) are not

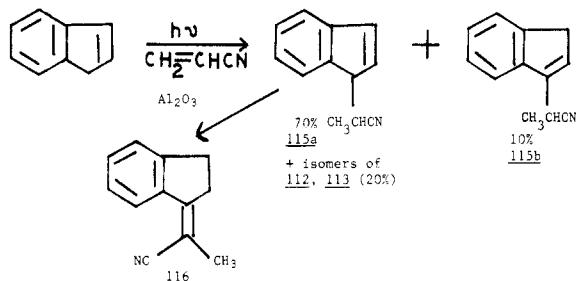

formed on direct irradiation of 1,1-dimethyl- or 1,1-diphenylindene with acrylonitrile, but the sensitized additions proceed normally to afford derivatives of 112 and 113.^{190b}

Sensitized additions of indene to maleic anhydride¹⁹² and to various halogenated ethylene derivatives have also been described.^{193,194} Good yields of adducts corresponding to 112 and 113 are obtained, and some of these compounds are synthetically useful,¹⁹²⁻¹⁹⁴ as are the acrylonitrile adducts.¹⁹⁵

Related to the above indene additions is Michler's ketone-sensitized addition of the trimethylsilyl enol ether of 1-indanone (117) and acrylonitrile, methyl acrylate, or methyl vinyl ketone.¹⁹⁶

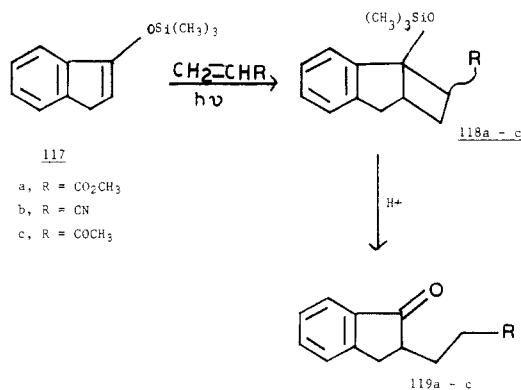

The initially formed cyclobutanes 118 can be converted to the ring-opened products 119 by mild acid

hydrolysis.¹⁹⁶ Similar ring-opening reactions are observed with the adducts of 1- and 2-naphthols and acrylonitrile.¹⁵²

3. Stilbenes

Although less well-known than *cis-trans* isomerization¹⁹⁷ or photocyclization of *cis*-stilbenes,^{198,199} a number of dienes and ethylenes undergo cycloaddition to certain stilbene derivatives. These systems also form singlet exciplexes, and Lewis and co-workers have utilized the reactions in mechanistic work.^{38,200,202}

For example, diphenylvinylene carbonate (120) adds to 1,3-dienes and to vinyl ethers to form cyclobutane adducts, the products being the same on direct and on sensitized (Michler's ketone) irradiation.^{200,201} Typical products are those from cyclopentadiene and 2,5-dimethylhexadiene (121-124).

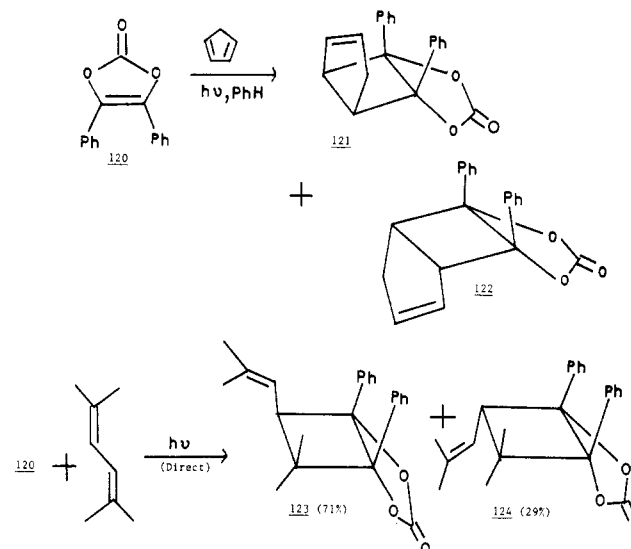

The ratio 121:122 is 4:1 on direct irradiation and 1:9 on sensitized excitation.²⁰⁰ When *cis* or *trans* dienes are used, e.g., piperylenes, the stereochemistry of the diene is retained in the direct (singlet) irradiation, which is not consistent with a biradical intermediate. However, limiting quantum yields for these additions are less than unity (0.5-0.8), and some intermediate capable of decaying to ground-state reactants is required.²⁰⁰ The reactions can proceed via singlet or triplet states, and exciplex intermediates are apparently involved.

The fluorescence of *trans*-stilbene is quenched by the electron-poor alkenes dimethyl fumarate and fumaronitrile,²⁰² and quenching is accompanied by the appearance of exciplex fluorescence in nonpolar solvents. The Stern-Volmer quenching constants for a series of electron-poor alkenes increase with increasing electron affinity, which indicates charge-transfer character in the exciplex, with *trans*-stilbene as donor.

The stilbene-dimethyl fumarate exciplex forms a single cycloadduct, dimethyl μ -truxinate 125, while re-

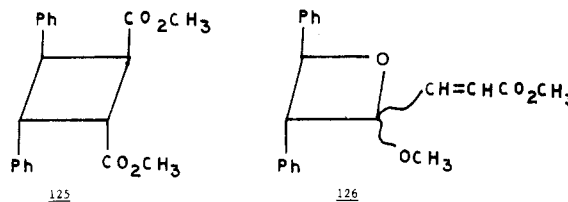

action of the stilbene excimer with dimethyl fumarate forms oxetane **126** and not the cyclobutane.

Oxetane formation on photoaddition to ground-state carbonyl compounds is rare, but one other example is the addition of phenanthrene and dimethyl fumarate, which also gives oxetane and cyclobutane adducts.²⁰³

4. Phenanthrenes

Like the stilbene and naphthalene additions, photocycloaddition of olefins to phenanthrenes has provided important clues to the mechanism of photoadditions generally.^{37,100,204-207} Cyanophenanthrenes form fluorescent exciplexes with alkenes, particularly styrene derivatives, and this has been utilized in photochemical work.^{37,204,205}

Phenanthrene itself adds to several electron-poor ethylenes including maleic and fumaric acid derivatives,^{203,206,208} chloroethylenes,²⁰⁹ and acrylonitrile.²⁰⁹ Addition always occurs at the 9,10-double bond and, except for the oxetane formed from dimethyl fumarate,^{203,206} the products are cyclobutanes. The reactions occur both on direct and triplet-sensitized irradiation, although oxetane formation is only observed on direct irradiation.²⁰⁶

A single adduct, **127**, is formed on addition of maleic anhydride, while addition of dimethyl maleate or fumarate affords two isomers, **128** and **129**, owing to cis-trans isomerization of the ester.

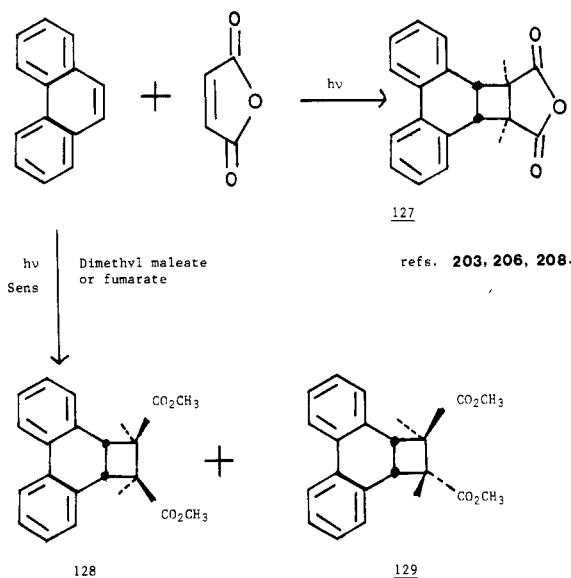

IV. Exciplexes as Reaction Intermediates

A. Experimental Evidence

Intermediacy of exciplexes and the effects of structure on regiochemistry and stereochemistry have all been considered for reactions of 9-cyanophenanthrenes and various styrenes.^{37,100,204,205,207} Some of these reactions are shown below.

The above reaction is noteworthy in that it was the first case in which an emitting exciplex was shown to be the precursor of cycloaddition products.^{100,204} In benzene solution, exciplex fluorescence from **130a** and **131a** is observed with $\lambda_{\max} = 435$ nm. This fluorescence

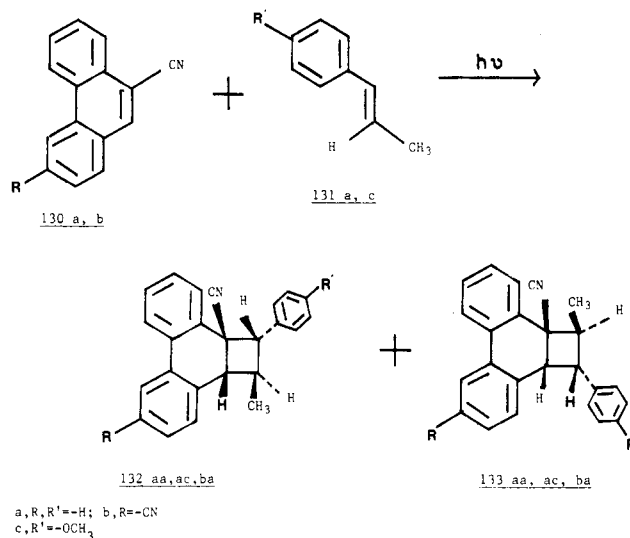

is quenched by added dimethylacetylene dicarboxylate, with a Stern-Volmer slope $K_{SV} = 64$ M⁻¹. The cycloaddition reaction (formation of **132ac** and **133ac**) is quenched with $K_{SV} = 62$ M⁻¹. This result requires that the emitting exciplex is an intermediate in the cycloaddition reaction or is in equilibrium with such an intermediate.^{100,204} The former explanation is in reasonable agreement with theory¹² and with experimental results on other singlet additions.

Some of the cyanophenanthrene-styrene additions can occur via triplet states, e.g., addition of 3,9-dicyanophenanthrene (**130b**) and *trans*- α -methylstyrene (**131a**).^{100,207} In this addition, the head-to-head and head-to-tail adducts (**132ba** and **133ba**, respectively) are formed in approximately equal amounts in the direct irradiation.²⁰⁷ Sensitization (Michler's ketone) affords only head-to-head adduct (**132ba**). In contrast, direct irradiation of 9-cyanophenanthrene and *trans*-anethole gives only head-to-head addition product.¹⁰⁰

This is a suitable point for discussion of regioselectivity in these addition reactions. In many of the reactions described, selectivity with respect to position and orientation of cycloaddition is observed. For example, addition of ethylenes to substituted naphthalenes usually occurs at the substituted double bond of the naphthalene, with the orientation expected for the "most stable diradical" intermediate.¹⁵⁵⁻¹⁵⁸

Frontier orbital theory (PMO theory)²¹⁰ has been used with some success to account for regiochemistry of stilbene-diene²¹¹ and 9-cyanophenanthrene-styrene¹⁰⁰ additions. Addition of singlet stilbene to various dienes (e.g., 1,3-pentadienes) occurs at the more substituted double bond of the diene.²¹¹

The orbital interaction diagram for stilbene ¹S and a conjugated diene is shown in Figure 14.²¹¹ For a concerted cycloaddition, interaction of the lowest unoccupied (LU-LU) and highest occupied (HO-HO) molecular orbitals is involved. Both of these interactions contribute to stabilization, and the stabilization energy is given by eq 52.

$$\Delta E = \frac{(C_{HOs1}C_{HOd1} + C_{HOs2}C_{HOd2})^2\gamma^2}{E_{HOs} - E_{HOd}} + \frac{(C_{LUs1}C_{LUd1} + C_{LUs2}C_{LUd2})^2\gamma^2}{E_{LUs} - E_{LUd}} \quad (52)$$

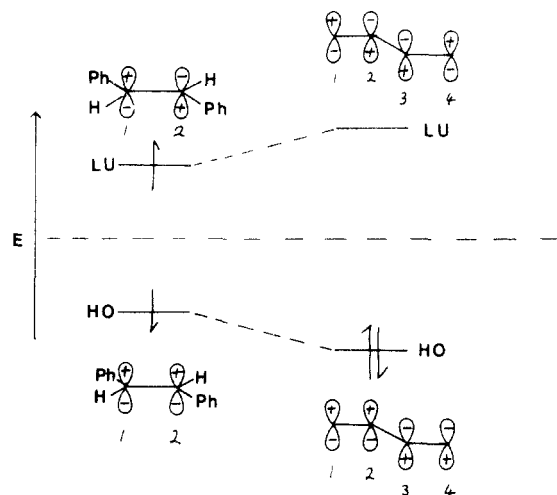

Figure 14. Orbital interaction diagram for excited *trans*-stilbene with butadiene. From ref 211.

C_{HOs1} and C_{LUd1} are the coefficients of the stilbene C-1 HO orbital and the diene C-1 LU orbital, respectively, and γ is the resonance integral between the interacting orbitals. $E_{HOs} - E_{HOd}$ is the energy separation between the interacting orbitals (Figure 14), which is estimated from ionization potentials and singlet excitation energy. The preferred regioisomers will be determined by the diene HO and LU coefficients. CNDO calculations afforded the coefficients, which led to prediction of addition to the more substituted diene double bond, in agreement with experiment.²¹¹

A similar approach was used to explain the addition orientation and stereochemistry of 3,9- and 3,10-disubstituted phenanthrenes and styrenes.¹⁰⁰ In a few cases, incorrect predictions of orientation were obtained, but generally the agreement with experimental results was fair. The theory predicted a strong dependence for endo vs. exo phenyl group stereochemistry in the adducts, also in agreement with experiment.

Although frontier orbital theory and the most stable biradical rule often predict the same orientation on addition, this is not always the case. Many 1,2-additions to dienes occur at the less substituted double bond.²¹¹ However, these may be stepwise reactions where the transition state resembles the biradical.

In general, exciplexes that emit fluorescence can be positively identified as reaction intermediates if a quencher for the exciplex can be found. Exciplexes have, in fact been quenched by "charge transfer quenchers",^{100,136b,204,205} by energy transfer,¹⁴ by polar solvents,⁶ and by added salts.³²

Charge-transfer quenchers, which quench by chemical reaction with the exciplex, were used by Caldwell and co-workers^{204,205} in their studies of the 9-cyanophenanthrene-alkene reactions. Rate constants for quenching of several singlet exciplexes (eq 53–56) and

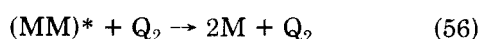
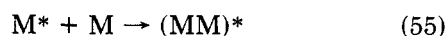
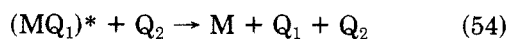
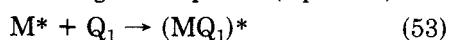

of corresponding monomeric arenes by various electron donors and acceptors were reported.¹⁸¹

SCHEME III. Two-State Mechanism for Reaction of 1-NN with Alkenes

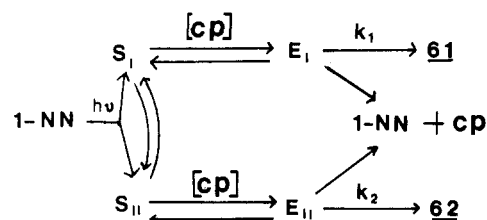

(CP = 1,2-dimethylcyclopentene)

Complexes studied included the pyrene excimer and a number of phenanthrene-alkene exciplexes. Quenchers (Q_2) used were amines and various alkenes. Photophysical data for the monomers, quenchers, and exciplexes as well as rate constants for exciplex quenching were given.²⁰⁵ The results were explained by a frontier orbital theoretical treatment, from which reasonable rates for quenching of any exciplex or excimer by a given donor could be predicted.

In some cases, exciplex quenching is accompanied by the appearance of a new fluorescence.^{205,212} For example, when the 3,10-dicyanophenanthrene-*trans*-anethole exciplex (MQ_1^*), $\lambda_{max} = 466$ nm) was quenched with diethylaniline, a new species (MQ_2^*), $\lambda_{max} = 535$ nm) is formed and an isoemissive point at 519 nm is observed.²¹²

An exciplex exchange or substitution reaction was proposed in which quenching of one exciplex leads to another (eq 57). This process was observed for several

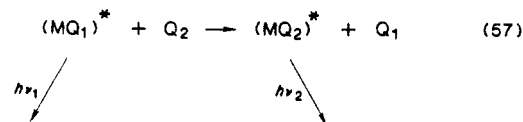

exciplexes and various amines, and some thermodynamic and kinetic data were determined.²¹² Apparently, termolecular processes are quite important in exciplex chemistry.

Exciplexes were also shown to be intermediates in the photoaddition of 1-naphthonitrile derivatives and alkenes.^{14,136b} Products of these reactions were described earlier (61–64). For the addition of 1-naphthonitrile and 1,2-dimethylcyclopentene^{136b} in hexane, kinetic studies indicate that cyclobutanes 61 and azetine 62 are derived from a single exciplex which is formed reversibly, as in Scheme I. The product ratios are independent of alkene and 1-naphthonitrile concentrations, and the temperature dependence is as expected for competitive reactions from a common intermediate.^{136b}

However, in moderately polar solvents such as ether and tetrahydrofuran/ether, various pieces of evidence show that the simple mechanism of Scheme I is untenable. In order to account for wavelength dependence, alkene concentration dependence, and the effect of oxygen quencher, a more complex scheme was proposed. This is shown in Scheme III, which proposes two naphthonitrile excited states, leading to two different exciplexes. The latter give rise to the two kinds of products—cyclobutane and azetine. When singlet quenching is slower than singlet-state equilibration, the product ratio will be independent of alkene or quencher (oxygen) concentration. This is the case in hexane, where exciplex formation is reversible at ordinary tem-

peratures (20 °C).¹¹ However, in ether solution, exciplex formation is largely irreversible,³⁶ and the azetine/cyclobutane ratio decreases with increasing 1,2-dimethylcyclopentene concentration from the hexane value, to a limiting value of 0.39. An alternate kinetic scheme, in which the cyclopentene assists or retards formation of one of the products by interception of one exciplex,¹⁴⁶ was discounted by the authors. Exciplex interception would require unreasonably high rate constants, and this scheme would not explain the wavelength dependence of the reaction.^{136b} We are inclined to favor this contention, since we observed that the lifetime of the 4-methyl-1-naphthonitrile-tetramethylethylene exciplex, in benzene, was essentially independent of alkene concentration up to 3.0 M.¹⁴

Finally, an assignment of the proposed 1-naphthonitrile excited states was made on the basis of fluorescence polarization and molecular orbital calculations.^{136b}

We have investigated exciplexes and photoadditions of 2- and 4-methyl-1-naphthonitrile and tetramethylethylene (TME).^{4,6,14} Products **63a** and **64** are obtained from 2-methyl-1-naphthonitrile and TME on irradiation in benzene, but 4-methyl-1-naphthonitrile and TME give cyclobutane **134** as the only product.¹⁴

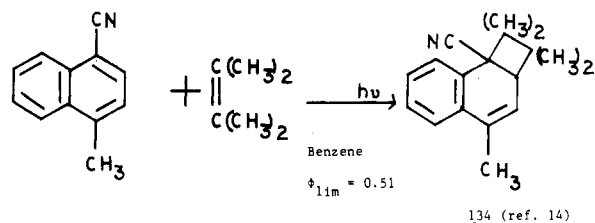

Exciplexes of both these methyl-naphthonitriles and TME fluoresce in nonpolar or medium-polarity solvents,¹⁴ and a kinetic study showed that they are similar to the 1-naphthonitrile-alkene exciplexes.^{11,36} The temperature dependence of the exciplex:monomer fluorescence ratio is shown in Figure 8. At temperatures above +5 °C (hexane, benzene, or ethyl acetate), the exciplexes are formed reversibly, while below -5 °C, they are formed irreversibly.

The exciplex fluorescence of 4-methyl-1-naphthonitrile-TME in ethyl acetate at -14.5 °C was quenched by 4.3×10^{-3} M biacetyl, and cycloaddition (formation of **134**) was similarly quenched.¹⁴ This requires that the emitting exciplex is an intermediate in the cycloaddition reaction.

Although biacetyl is a well-known quencher of singlet excited states,⁹ it had not been used previously to quench exciplexes. Energy transfer from the exciplex to biacetyl (eq 58) is exothermic by about 5 kcal/mol,

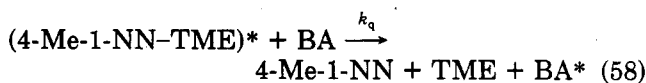

and k_q should be diffusion controlled.

The measured exciplex lifetime (20 ns) gave a quenching rate constant of $k_q = 1.24 \times 10^{10} \text{ M}^{-1} \text{ s}^{-1}$. With respect to energy transfer, the exciplex is behaving like an ordinary excited state.

Solvent effects on exciplexes can be complex, particularly in the medium-polarity range.^{45,213} However, the formation of ion pairs in polar solvents, which results in exciplex fluorescence quenching, is often ac-

companied by quenching of cycloaddition.^{6,213} This does not prove the exciplex is an intermediate in cycloaddition, but is a good indication.

Evidence for intermediacy of nonemitting exciplexes is often indirect, but convincing cases have been presented for a number of reactions.

Negative temperature dependencies of the Stern-Volmer constants of *trans*-stilbene-tetramethylethylene,²¹⁴ anthracene-2,5-dimethyl-2,4-hexadiene (DMH),¹⁷⁵ and 9,10-dichloroanthracene-1,3-cyclohexadiene (CHD)¹⁸⁵ have been reported. This is consistent with quenching via exciplex formation, since if exciplex dissociation (k_4 in Scheme I) is more temperature dependent than the other rate constants, K_{SV} will decrease with increasing temperature (see, however, ref 140a).

Additional evidence was obtained in the 9,10-dichloroanthracene-CHD case, since the exciplex can be intercepted by pyridine, which decreases the adduct quantum yields.^{154,185}

Earlier reports that dienes enhance anthracene dimerization were contradicted by recent work.^{183,184} In fact, dienes reduce the dimerization quantum yield, and the proposed interception of diene-anthracene singlet exciplexes by anthracene apparently does not occur.

However, interception of the coumarin excimer by tetramethylethylene has been postulated on the basis of kinetic evidence.²¹⁵ Photoaddition of coumarin and TME gives mixed adduct **135** with considerable quenching of the coumarin dimerization.

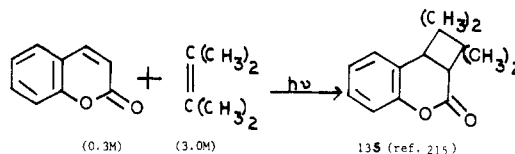

At these molarities, in order to quench coumarin dimerization to the extent observed, TME would have to react with coumarin ¹S, faster than the diffusion-controlled rate. This results from the short lifetime of the coumarin singlet, and interception of a longer lived species (the coumarin excimer) was proposed.

Cycloadditions to coumarins are of some practical importance. The psoralens, which are a group of furcoumarins widely used in photochemotherapy, owe their pharmacological activity to additions at the coumarin ring.²¹⁶

Cycloadditions of 8-methoxypsoralen (**136**) to fumaronitrile, dimethyl fumarate, and TME have been studied in methanol and benzene solution. Irradiation of **136** at 300 nm gives **134** with TME and **138** with fumaronitrile.²¹⁶ Addition of fumaronitrile and di-

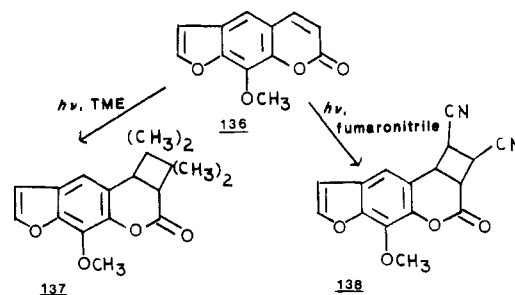

methyl fumarate was proposed to involve a singlet exciplex, but a triplet mechanism could not be ruled out for addition of TME.²¹⁶

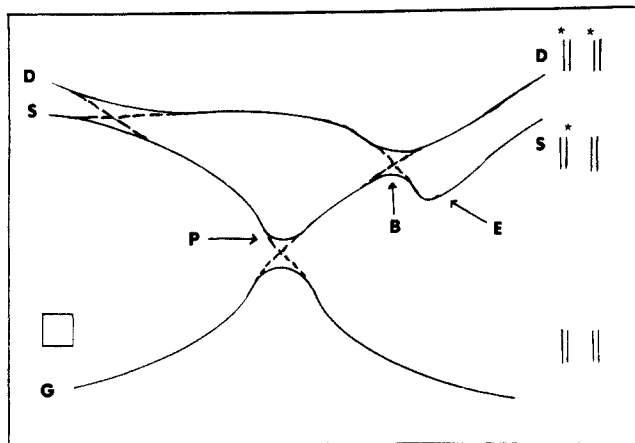

Figure 15. Energy vs. reaction coordinate for the 2 + 2 cycloaddition, showing the ground state (G) and singly (S) and doubly (D) excited states. The fluorescent exciplex is at E, the pericyclic minimum at P. From ref 12.

In general, inefficiency in a photoaddition reaction, as measured by the sum of limiting quantum yields for addition, intersystem crossing, and exciplex fluorescence, is evidence for some bimolecular intermediate, which can form adducts or decompose to ground-state reactants. The cycloadditions of naphthalene and acrylonitrile³ and of benzene and dioxoles¹⁴⁶ and the dimerizations of 1,2-diphenylcyclobutene²¹⁷ and indene may be cited as examples.²¹⁸ This inefficiency does not require exciplex or excimer intermediates, since other intermediates, e.g., 1,4-biradicals, could be implicated. However, when combined with other data, a good case for exciplex intermediates can often be made.^{3,146}

Exciplexes of anthracene and *N,N*-dimethylaniline are intermediates in amination and photoreduction of anthracene.^{219,220} They can be intercepted by a second dimethylaniline molecule. The original papers^{219,220} should be consulted for details.

B. Exciplex Formation, Decay, and Potential-Energy Surfaces

Energy profiles for the three electronic states involved in 2 + 2 cycloaddition are shown in Figure 15. Two ethylene molecules are shown to react, forming cyclobutane. Although this picture is derived from theory,¹² it satisfactorily accounts for several important observations on exciplex chemistry and has been used in many previous discussions.^{14,37,38} Surfaces for the ground-state (G) first singlet excited state (S) and doubly excited state (D) are shown. D is reached by surface crossing from S, and the crossing from S involves passage over an energy barrier (B). Return to ground state occurs at P, which is a minimum in surface D called a "funnel" or a "pericyclic minimum". Fluorescence, if observed, occurs from E (cf. Figure 1).

According to this model, cycloadduct formation and internal conversion should both be activated processes. This has been confirmed for reactions of cyanophenanthrenes with styrenes³⁴ and for phenanthrene with dimethyl fumarate,²²¹ all of which involve exciplex intermediates. Activation parameters were obtained from the temperature dependence of rate constants. The radiative decay constant (fluorescence from E) was assumed²²¹ to be temperature independent.³⁶ Products of the direct irradiation of phenanthrene and dimethyl

TABLE III. Activation Parameters for Exciplex Processes in Phenanthrene-Dimethyl Fumarate Addition^a

	A, s^{-1}	$E_a, kcal/mol$	$\Delta S^\ddagger, eu$	$\Delta H^\ddagger, kcal/mol$
k_{CB}	6.0×10^{11}	7.9	-6.8 3	7.3 1
k_X	1.0×10^{11}	5.0	-10.3 2	4.4 0.65
k_D	7.7×10^{10}	2.8	-10.9 1.5	2.2 0.45

^a Reference 221.

TABLE IV. Rate Constants for Reactions of Exciplexes^a

exciplex	$T, ^\circ C$	$10^{-6}k_{cyclo}$	$10^{-6}k_{decay}$	$10^{-6}k_{fluor}$
139c-140a	23	280	210	34
139b-140a	20.4	42	32	4.3
139a-140a	20.5	4.6	4.4	3.6
139b-140b	20.1	0.56		4.2

^a References 37, 221b.

fumarate are cyclobutanes 128 and 129 and an oxetane corresponding to 126.²⁰⁶ Although some cycloaddition occurs via intersystem crossing, a kinetic analysis showed that cyclobutane 129 and the oxetane are partially formed directly from singlet exciplex (E).²⁰⁶ Activation parameters for cyclobutane (k_{CB}), oxetane (k_X), and internal conversion (k_D), originating in E, are given in Table III. All three processes are clearly activated, as shown by the Arrhenius activation energies (E_a) and enthalpies of activation (ΔH^\ddagger). Interestingly, ΔH^\ddagger for internal conversion is different from either of the chemical processes, perhaps indicating that a different exciplex geometry is required for decomposition as opposed to collapse to cycloadducts. All three processes also have negative entropies of activation, showing that the transition states are significantly more ordered than the exciplex.

By use of phenanthrenes (139) and styrenes (140) with different substituents, the structures, and hence the exciplex stabilities, were varied.^{37,221b} The more

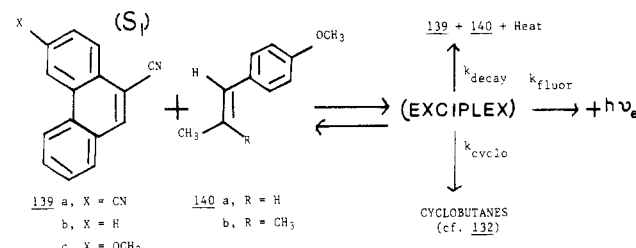

stable exciplexes (as measured by the extent of charge transfer) are longer lived, fluoresce more strongly, and have lower rate constants for cycloaddition and decay.^{37,221b} Products were cyclobutanes corresponding to 132. Some rate constants obtained are shown in Table IV. Although the absolute values of k_{cyclo} and k_{decay} vary over a wide range, their ratio remains roughly constant and, except for one case, the radiative decay (k_{fluor}) is independent of structure. Also, intersystem crossing is almost independent of structure ($k_{isc} = (17-34) \times 10^6 s^{-1}$).

These results can be rationalized by using the energy diagram shown in Figure 15. Since both cycloaddition and internal conversion are activated processes, factors that stabilize the exciplex (E) will slow both processes by increasing the height of the barrier (B). Thus, it becomes apparent why nonfluorescent exciplexes are often chemically reactive and vice versa, the height of barrier B being the important factor.

TABLE V. Decay Constants of 1-Naphthonitrile-TME Exciplexes

solvent	$10^{-7}k_{\text{cyclo}}, \text{s}^{-1}$	$10^{-7}k_{\text{decay}}, \text{s}^{-1}$	$10^{-7}k_f, \text{s}^{-1}$
hexane	5.7	20.0 ± 5	$1.30^a (1.15)^b$
benzene	1.3	7.0 ± 2	$0.90 (0.83)^b$
dimethoxyethane	2.6	9.0 ± 2	$0.52 (0.38)^b$
<i>tert</i> -butyl alcohol			$0.38 (0.22)^b$

^a 1-Naphthonitrile-TME. ^b 1-Naphthonitrile-1,2-dimethylcyclopentadiene. Temperature was 22 °C.

Although the above interpretation, based on the energy profile shown in Figure 15, is reasonable, alternate theoretical²²² and experimental²²³ approaches indicate that internal conversion directly from exciplex ¹S (E in Figure 15) is also a possibility. This may be true for more stable exciplexes, which are often chemically unreactive, but more work on radiationless processes is required to determine the relative importance of "activated" vs. "physical" internal conversion.

Exciplex fluorescence is often red-shifted in polar solvents, indicating that the exciplex is being stabilized. On the basis of the model shown in Figure 15, rate constants k_{cyclo} and k_{decay} should decrease as the solvent polarity increases. This has been observed for reactions of 1,2-diarylethylene-diene²¹³ and 1-naphthonitrile-TME²²⁴ exciplexes. Rate constants for the latter are shown in Table V.

Essentially one cycloaddition product (cyclobutane 63) was formed in each of the solvents hexane, benzene, and dimethoxyethane, and k_{cyclo} and k_f were obtained from quantum yields and lifetimes by using eq 11 and 12. Other products were obtained in *tert*-butyl alcohol, and the quantum yield of addition was not measured. Decay rate (k_{decay}) was obtained by difference but should represent internal conversion since intersystem crossing in these exciplexes seems to be inefficient.¹⁴

There is a sharp decrease in k_{cyclo} and k_{decay} in benzene or dimethoxyethane vs. hexane. The smaller values in benzene relative to the values in the more polar dimethoxyethane are reasonable in that benzene and other arenes are sometimes anomalous in their solvent effects on exciplexes and singlet lifetimes.^{14,51} Interestingly, the ratios $k_{\text{cyclo}}/k_{\text{decay}}$ are very similar in the three solvents, as was found for differently substituted phenanthrene-styrene exciplexes.^{37,221b} (See Table IV.)

The series of radiative decay constants (k_f) is also interesting. The observed decrease in k_f with increasing solvent polarity has been reported previously,^{45,213} but the trend with these naphthonitrile-alkene exciplexes is very well-defined. The trend is consistent with a change in the exciplex structure with increasing solvent polarity, in which the charge-transfer state makes an increasing contribution to the exciplex wavefunction; i.e., C_2 in eq 59 increases with solvent polarity.⁴⁵ $\Psi_{\text{exciplex}} = C_1\Psi(\text{NN}^*\text{TME}) + C_2\Psi(\text{NN}^-\text{TME}^+)$ (59)

tably, in hexane, where C_1 should be a maximum, k_f is almost the same as the reported value for uncomplexed 1-naphthonitrile ($1.0 \times 10^{-7} \text{ s}^{-1}$).³⁶

In summary, a reasonable interpretation of the effects of nonpolar and medium-polarity solvents on the three major exciplex decay pathways has been deduced. However, over a wider range of solvent polarities, quantum yields and exciplex lifetimes vary in a complex manner. For example, as solvent polarity is increased,

TABLE VI. Quantum Yields and Lifetimes for the 1-Naphthonitrile-TME Exciplex

solvent	$\Phi_{\text{cyclo}} \pm 15\%$	$\Phi_{\text{fluor}}^a \pm 20\%$	$\tau(\text{exciplex}),^b$ ns
hexane	0.22	0.050	3.8 (3.3) ^c
benzene	0.14	0.094	10.6
1,2-dimethoxyethane	0.025	0.051	9.7
<i>tert</i> -butyl alcohol		0.055	14.6
isopropyl alcohol			4.7

^a Exciplex cycloaddition and fluorescence at limiting TME concentration. ^b Lifetime at limiting TME concentration. ^c Value obtained by Ware et al., ref 11.

exciplexes become longer lived as the medium-polarity range is reached, but the lifetime decreases due to ion-pair formation in very polar solvents, e.g., acetonitrile or methanol.^{45,213,224} Some data for the 1-naphthonitrile-TME exciplexes are shown in Table VI.

In the above interpretation of rate constants for exciplex decay, electron-transfer processes were ignored for solvents less polar than *tert*-butyl alcohol.

Some ion-pair formation probably occurs even in dimethoxyethane, but not to a large extent. However, in isopropyl alcohol and more polar solvents, electron transfer has become a major decay pathway.

V. Photokinetics and Photochemistry of Bichromophoric Compounds

The physical and photochemical interactions between unsaturated groups can be influenced by linking them with saturated chains of various lengths. Most work has employed alkane chains,^{225,226} but ethers^{14,226-228} and esters²²⁹ have also been used. These compounds are called "bichromophoric compounds" and can have a wide variety of structures. For example, the chromophores can be identical or different, the chain length and structure can be varied, and one or more chains may be present, as in the cyclophanes. Additionally, many structures in which the chromophores are linked by a single, substituted sp^3 carbon undergo the di- π -methane rearrangement,²³⁰ which has no counterpart in the longer chain compounds. These fields have been reviewed.^{225-227,230} In this paper, specific topics are chosen that overlap with the author's interests or with the bimolecular processes already described.

A. Effects of the Linking Chain

1. General Considerations

Excimer or exciplex formation often precedes photochemical reactions, and the effects of linking on these photophysical processes will be considered first. A kinetic scheme for bimolecular exciplex formation is shown in Scheme I. The rate constant k_3 is largely determined by the medium and is often diffusion controlled. Similar kinetics apply to systems in which M and Q are linked with a very flexible chain (eq 60).

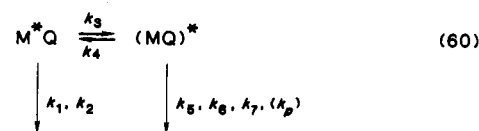

SCHEME IV

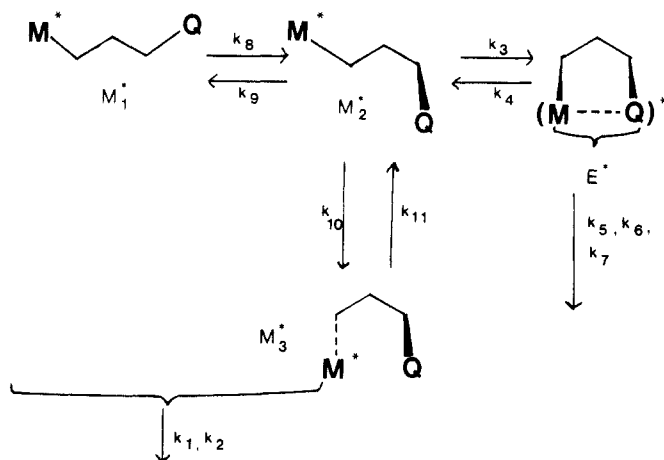

Consider now a system where M and Q are linked by a three-atom chain, which can adopt the conformations shown in Scheme IV.²²⁸ Rate constants k_1 – k_7 are equivalent to those in Scheme I (though not necessarily equal in magnitude), while k_8 – k_{11} are the same as the ground-state rates of bond rotation. The excited monomers M_1^* , M_2^* , and M_3^* will have the same populations immediately after excitation as in the ground state, and the exciplex (E) cannot be populated by direct excitation but only via M_2^* . Compounds exhibiting these kinetics are 141 and 142, which have been studied by steady-state and transient methods.^{228,231}

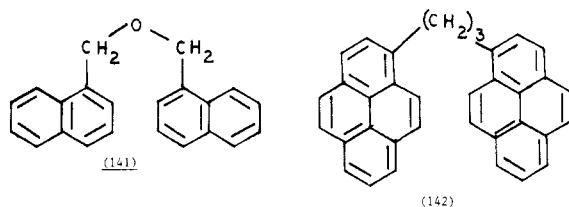

It was noted earlier that the classical exciplex kinetics of Scheme I results in double-exponential fluorescence time dependencies for exciplex and monomer in the appropriate temperature range (eq 13 and 14). In general, the number of exponential terms is equal to the number of *kinetically distinguishable* species interconverting in the excited state.^{228,231} Thus, schemes with two conformationally different monomers and one exciplex or one monomer and two exciplexes will both give three exponential terms in the monomer ($I_M(t)$) and exciplex ($I_E(t)$) fluorescence response functions.

This has been shown for 1,3-di(1-pyrenyl)propane (142),²³¹ where the response functions have the form

$$I_M(t) = A_{11}e^{-\lambda_1 t} + A_{12}e^{-\lambda_2 t} + A_{13}e^{-\lambda_3 t} \quad (61)$$

$$I_E(t) = A_{21}e^{-\lambda_1 t} + A_{22}e^{-\lambda_2 t} + A_{23}e^{-\lambda_3 t} \quad (62)$$

It was concluded, from an analysis of the decay parameters, that one excited monomer and two excimers are involved in the excimer formation for 1,3-di(1-pyrenyl)propane (142).^{231b} The kinetic scheme is shown in eq 63.

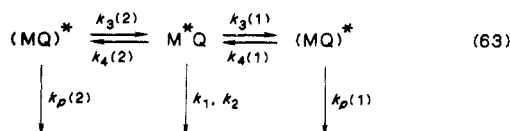

The rate constants for excimer formation $k_3(1)$ and $k_3(2)$ differed by a factor of 2 and were dependent on solvent viscosity (heptane vs. hexadecane). The excimers were less stable ($\Delta H = -5.25$ kcal/mol) than the intermolecular pyrene excimer ($\Delta H = -10.5$ kcal/mol).

In contrast, the fluorescence decays of 1,3-di(2-pyrenyl)propane were fitted to double-exponential equations, and only one monomer and one excimer were needed in the kinetic scheme. This is shown in eq 60. The double-exponential decay was found over a wide temperature range (-90 to $+90$ °C), showing that the double-exponential decay was not just a limiting situation of more complex kinetics due to the temperature dependence of certain rate constants.^{231b}

In practice, three exponential terms are not always observed when three excited species are involved, but the presence of different monomer conformations can still show up in the transient kinetics. An interesting example is that of the phenyl- and naphthylaminoalkanes 143a and 144.²³²

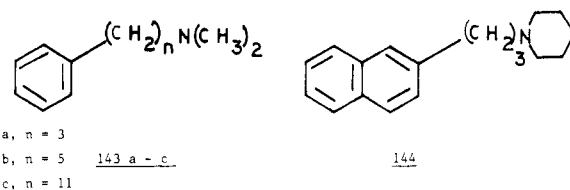

In the example used above (eq 60), where M^* and Q are linked by a very flexible chain, the kinetics should be the same as for bimolecular exciplex formation (Scheme I). The temperature dependence of the kinetics should also be the same as for bimolecular complex formation.

In the intermediate temperature range, monomer and exciplex fluorescence decays are described by double-exponential eq 13 and 14. At low temperature, however, these kinetics give single-exponential decay for monomer fluorescence since k_4 can be neglected (eq 64).

$$[M^*] = ce^{-(k_1+k_2+k_3)t} \approx ce^{-k_3 t} \quad (64)$$

The monomer fluorescences of 143a and 144 are, however, described by double-exponential equations even at low temperatures, showing that kinetics are more complex than shown in Scheme I or eq 60.

In the case of 144,²³² the monomer fluorescence intensity in *n*-butyl acetate at -70 °C is described by eq 65, where $\lambda_2^{-1} = 14$ ns and $\lambda_1^{-1} = 70$ ns. The fluores-

$$I_M(t) = [M^*] = C_1 e^{-\lambda_1 t} + C_2 e^{-\lambda_2 t} \quad (65)$$

cence lifetime of β -methyl-naphthalene under the same conditions is 70 ns, and the long-lived component of eq 65 is attributed to conformations that cannot form exciplex within the monomer lifetime.²³²

The linked alkene-1-naphthonitrile 145 shows exciplex fluorescence similar to that of the bimolecular cases¹⁴ (see Figure 7). The photokinetics of 145 were

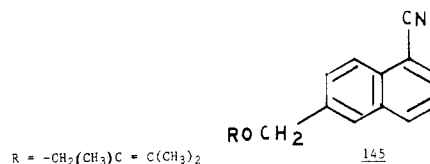

studied in the temperature range 0–40 °C.²³³ Both monomer and exciplex time dependencies exhibit three exponential terms, although one component of the

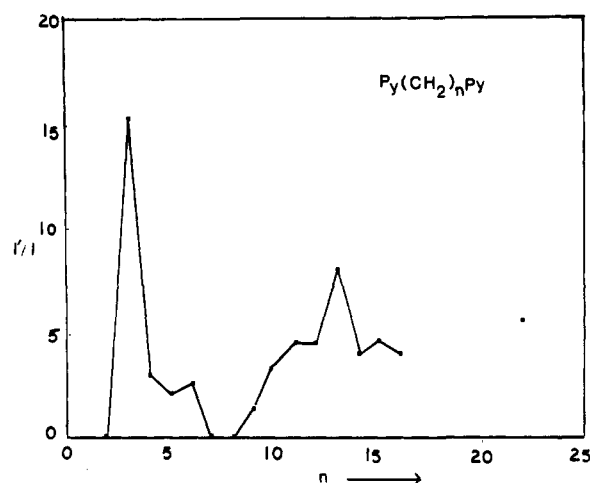

Figure 16. Dependence of the ratio of excimer fluorescence intensity (I') to monomer fluorescence intensity (I) on chain length for a series of α,ω -di-(1-pyrenyl)alkanes. Solutions were 10^{-5} M in methylcyclohexane. From ref 239.

monomer decay is short-lived and is only resolved at the lower temperatures. Molecular mechanics calculations suggest that two conformations of 145 exist, and the exciplex could form rapidly from one but only slowly from the other. It is possible that the bulky tetramethylethylene group slows down rotations about the ether chain, which would otherwise be rapid. Recent work has shown that, in very crowded ethers, rotations about the carbon-oxygen bonds can be correlated in a gear-meshing fashion.²³⁴

2. Effect of Chain Length on Exciplex Formation

In the above discussions, most examples have linking chains with three atoms. This is particularly favorable for interactions between the chromophores, but an increasing amount of work has shown that these interactions can occur with other chain lengths.^{229b,235-239}

In the series of α,ω -diphenylalkanes ($\text{Ph}(\text{CH}_2)_n\text{Ph}$), excimer fluorescence is only observed when $n = 3$ and not when $n = 1, 2, 4, 5,$ or 6 .²³⁷ Similarly, intramolecular excimer formation at room temperature was found only for α,α - and β,β -dinaphthylpropanes.²³⁸

However, in a study²³⁹ of α,ω -dipyrenylalkanes ($\text{Py}(\text{CH}_2)_n\text{Py}$), where $n = 1-16$ and 22 , it was found that all the compounds exhibited excimer fluorescence (cf. Figure 2), except where $n = 1$ or 7 . The intensity of this fluorescence depended on chain length and was particularly intense when $n = 3$ (compound 142), but it was of low intensity when $n = 2$ or 8 . The fluorescence spectrum and lifetime of $\text{Py}(\text{CH}_2)_7\text{Py}$ were identical with those of 1-methylpyrene, confirming that no excimer formation occurs.

Dependence of the excimer:monomer fluorescence intensity ratios on the number of methylene groups (n) is shown in Figure 16.²³⁹ To organic chemists, this is an interesting result because the intensity ratios parallel the yields²³⁹ and rates²⁴⁰ of ring-closure reactions, as a function of ring size.

The photophysics of compounds containing arene and dimethylamino groups linked with chains of different lengths has been widely studied.^{229b,235,236} Specific compounds include the phenylamino derivatives 143b,c ($n = 5, 11$),²³⁵ the ω -dimethylaminoalkyl esters of 2-anthracenecarboxylic acid ($n = 2, 3, 5, 9, 11$);^{229b} and

ω -(1-pyrenyl)- α -(dimethylamino)alkanes ($n = 2, 3, 4, 8$).²³⁶

In general, exciplex formation occurred with the longer chains ($n = 8, 9, 11$), but exciplex fluorescence was not always observed, even in low- or medium-polarity solvents.²³⁶ In the case of the ω -dimethylaminoalkyl esters of 2-anthracenecarboxylic acid ($A(n)D$),^{229b} exciplex formation in a nonpolar solvent only occurred with the longer chains ($n = 9, 11$) that can place the amino nitrogen over the central ring of the anthracene group. These $A(n)D$ derivatives have just two emitting excited states (eq 60), indicating that rotational barriers in the linking chains do not affect the kinetics significantly.

In acetonitrile, electron transfer occurs even for $A(n)D$ with $n = 2, 3,$ or 5 . This is evidenced by quenching of the monomer (anthracene) fluorescence, which does not occur for these chain lengths in nonpolar solvents,^{229b} and shows that electron transfer can occur over relatively large distances (≈ 9.0 Å) between A and D in $A(2)D$ and $A(3)D$. The ion-pair state formed in acetonitrile from the ω -(1-pyrenyl)- α -(dimethylamino)alkanes was observed by picosecond spectroscopy.²³⁶

To summarize, photophysical interactions between chromophores in linked systems can occur with different chain lengths. If the excited monomer is long-lived and the excimer (exciplex) has a large stabilization energy (ΔH), then excimer formation can be observed with many chain lengths.²³⁹ However, when the chromophore singlets are short-lived and the exciplex is weakly stabilized, internal exciplex formation only occurs in favorable cases, as with a three-atom chain.²³⁷ Electron transfer leading to solvated ion pairs seems to be less dependent on geometry than exciplex formation.

B. Effects of Linking Chain on Photoaddition Reactions

The linking chain in bichromophoric compounds can facilitate reactions that also occur in corresponding bimolecular cases and can also permit additions, not observed in the bimolecular situation. The latter are usually observed with a three-atom flexible chain or with molecules of fixed geometry, e.g., the cyclophanes. Thus, in reactions where an excimer or exciplex is intermediate, linking can affect both exciplex formation and its collapse to product.¹⁴

1. Systems with Three-Atom Chains

Although some naphthalene derivatives dimerize on irradiation, dimerization of naphthalene has not been observed. However, irradiation of α,α -dinaphthylpropane (146) affords the internal $4\pi_s + 4\pi_s$ cycloadduct 147.²⁴¹ Irradiation of the ether-linked compound 141 apparently yields two isomers, also $4\pi_s + 4\pi_s$ addition products, 148 and 149.²⁴²

Thermal rearrangements of 147 (refluxing CHCl_3) affords the cyclobutane isomer 150, and both 147 and 150 revert to the bis(naphthyl)propane (146) on irradiation at 254 nm.

Linking with a three-atom chain also facilitates in-

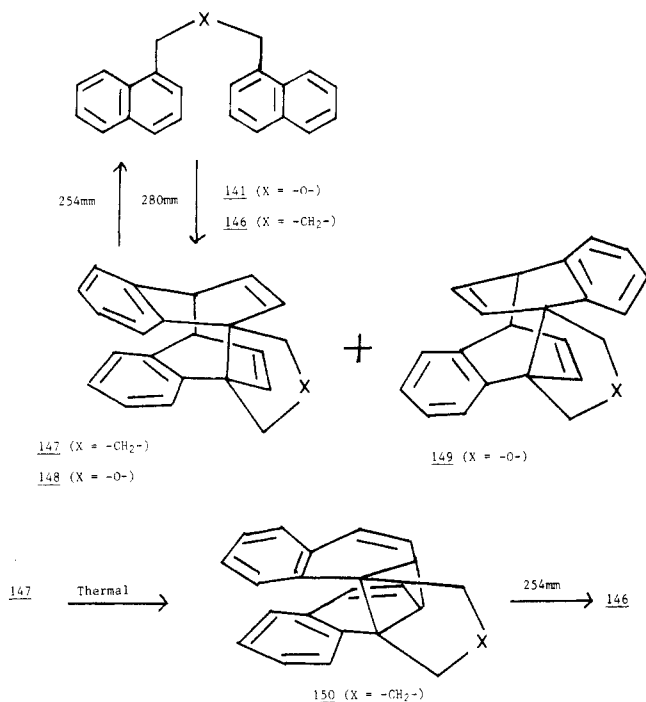

tramolecular addition of anthracene and naphthalene chromophores, a reaction that does not occur in bimolecular cases.^{243,244}

Photocyclization of linked anthracenes has been studied by the same group that investigated anthracene dimerization.^{81,82} They found that compounds such as 151 cyclized by addition of the 9,10-positions of both anthracenes, forming 152. Substituents R and R¹ were

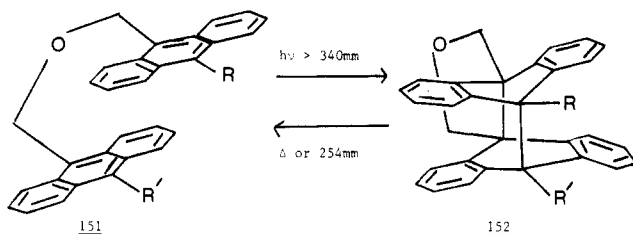

H, CH₃, and C₆H₅. However, when the anthracenes were linked with this chain at the 1,9'-positions or with the tetramethylsilyloxy chain at the 9,9'-positions, cyclization products 153 and 154 were obtained.^{204a}

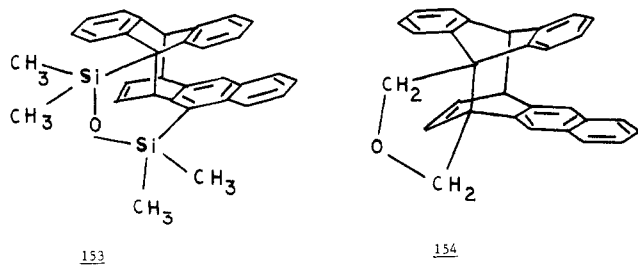

Thus, the restrictions of a linking chain can compel the chromophores to react in ways not observed in the absence of the restriction.

2. Linked Phenyl and Alkene Groups

Intramolecular photoaddition of alkenes to phenyl groups usually occurs (1,3-(meta))²⁴⁵ but several examples of 1,4-addition are also known.²⁴⁶ There are surprisingly few examples of 1,2-addition, but this should

be the major reaction in suitable bichromophoric compounds.

Morrison and co-workers²⁴⁵ have studied nonconjugated aryl olefins such as *cis*-6-phenylhex-2-ene (155a).

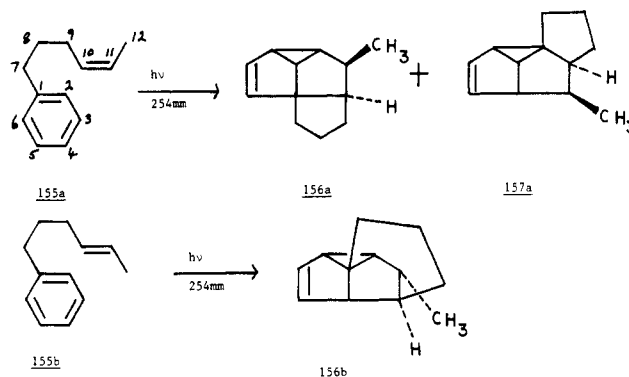

This compound forms internal 1,3-adducts 156a and 157a with higher quantum yield (0.26) than *Z* → *E* isomerization (0.01).

cis-6-Phenylhex-2-ene undergoes addition at positions 1 and 3 of the aromatic ring (numbering as in above formulas). Closure of the three-membered ring takes place between C-2 and either C-4 or C-6.

The major adduct (156b) from *trans*-6-phenylhex-2-ene (155b) is formed by addition at positions 2 and 6, followed by bond formation between C-1 and C-3.²⁴⁷ Bond formation between C-1 and C-5 does not occur, presumably because of steric strain in the adduct. In addition to the major adduct (156b), *trans*-6-phenylhex-2-ene yields a small amount (4%) of 1,3-adduct.²⁴⁷ The difference in behavior between the *cis* and *trans* isomers has been attributed to steric factors.

Cornelisse and co-workers²⁴⁷ have irradiated *trans*-6-phenylhex-2-enes with substituents (CH₃, OCH₃, CF₃, CN, F) at ortho, meta, and para positions in the aromatic ring. There are six possible products from the ortho- and meta-substituted compounds, and three from the para isomers. The results show that properly situated substituents are capable of changing the mode of addition from 2,6 (in the unsubstituted compound) to 1,3 or 1,5. For example, *o*-methoxy gives 49% 1,3-addition and *o*-trifluoromethyl 83% 1,5-addition. *p*-Cyano and *p*-trifluoromethyl give exclusively 1,3-addition. These substituent effects were rationalized in terms of the polarized intermediate that was proposed for the intermolecular additions.^{145c}

cis-Decalin 158 forms polycyclic 1,3-adduct 159, while irradiation of the linked acetylene 160 affords 161, presumably via initial 2 + 2 cycloaddition.²⁴⁵ The latter is inefficient, with a reported quantum yield of 3.3×10^{-3} .

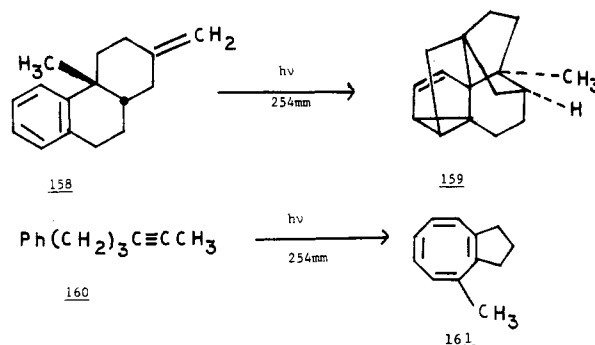

A study of a series of phenyl vinyl ethers ($\text{Ph}(\text{CH}_2)_m\text{O}(\text{CH}_2)_n\text{CH}=\text{CH}_2$) showed that 1,3-addition is the usual mode, but 1,4-adducts are formed with some chains.²⁴⁶ No exciplex fluorescence was observed, although the monomer (arene) fluorescence was strongly quenched by the alkene.

The features of intramolecular 1,3-addition that pertain to synthesis have been discussed,^{248,249} and the successful total syntheses of (\pm)- α -cedrene, isocomene, and hirsutene have been described.^{248a-c} This intramolecular addition is also the basis of a synthesis of "fenestranes", which are structures containing an sp^3 carbon distorted toward planarity.²⁴⁹ An example is the synthesis of 162 from 163 via the photoisomer 164.^{249b}

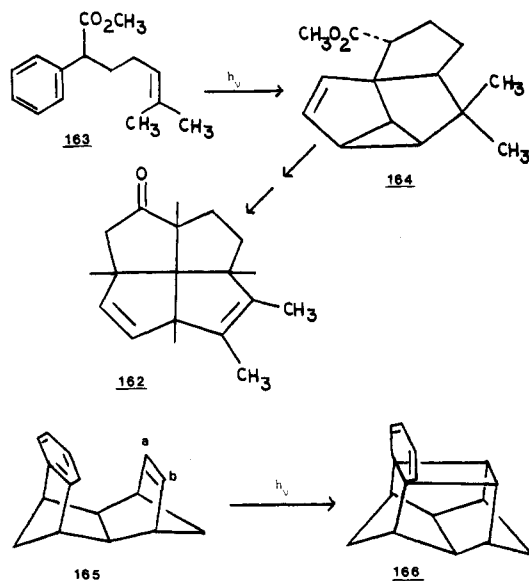

Intramolecular 2 + 2 cycloadditions between a benzene ring and an alkene double bond can occur in systems with fixed geometry.²⁵⁰ For example, the benzoene derivative 165 forms 166 on irradiation.

Cyclobutane formation also occurs if bond a-b is part of a second benzene ring,^{250b} but not apparently if it is an azoxy group.^{250a}

Photodimerization of benzene rings also occurs on irradiation of the layered, multiply-linked cyclophane 167.²⁵¹ The cage compound 168 is formed. The latter

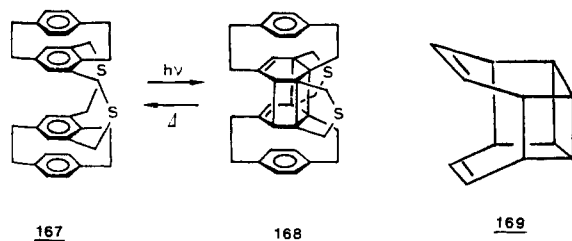

is relatively stable at room temperature, but reverts to cyclophane 167 when heated to 90 °C in solution. The oxygen and selenium analogues of 167 undergo similar reactions. The pentacyclic dimer of benzene 169, the ring system of which is present in 168, has been synthesized by an indirect photochemical route.²⁵²

3. Chromophores Linked with Two-Atom Chains. Cyclophanes

A considerable amount of work with 1,2-dianthryl-ethanes and [2.2]cyclophanes has now been report-

ed.^{225c,253-260} 1,2-Di(9-anthryl)ethane (170a) undergoes

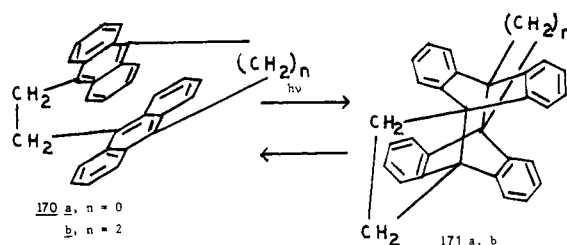

reversible photoisomerization giving 171a, whose crystal and molecular structures were determined by X-ray diffraction.²⁵³

Photodissociation of 171a in the crystal was found to give different conformations of 170a, depending on whether or not the light was strongly absorbed.²⁵³ Intramolecular addition of 170a was found to be independent of solvent polarity.²⁵⁴ Excimer fluorescence from 170a was observed, as it was for some [2.2]-anthracenophanes,^{254,255} and evidence was obtained for two different excimers of 170a.^{254,255}

[2.2](9,10)Anthracenophane (170b) photoisomerizes via a $4\pi + 4\pi$ cycloaddition giving 171b.²⁵⁶ A similar reaction is observed on irradiation of *syn*-[2.1]-(1,4)-anthracenophane.²⁵⁷ The internal dimer 173 is formed on irradiation of *anti*-[2.2](1,4)naphthalenophane (172),

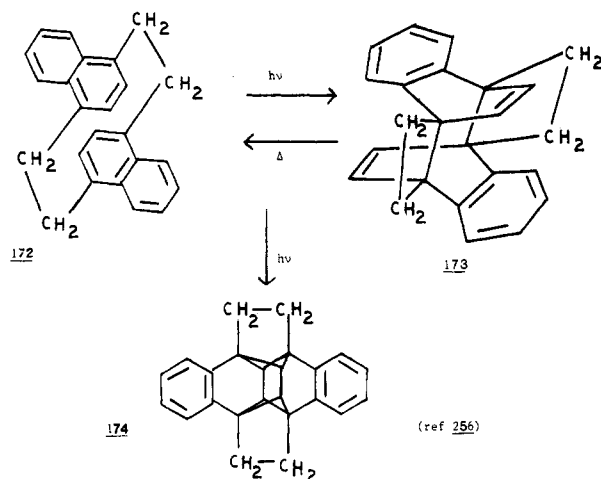

although the $4\pi + 4\pi$ product (173) is thermally unstable and after long irradiations the product of two $4\pi + 2\pi$ reactions (174) is obtained.²⁵⁶

It is interesting that, although simple (benzenoid) cyclophanes tend to undergo retroaddition on irradiation,²⁵⁸ some multilayered derivatives (e.g., 167) photoisomerize, forming cage structures.²⁵¹

The above 4 + 4 internal additions of bis(anthracene)s are all singlet processes. On triplet sensitization with biacetyl, 1,2-di(9-anthryl)ethane (170a) forms an internal 4 + 2 adduct (175).²⁵⁹

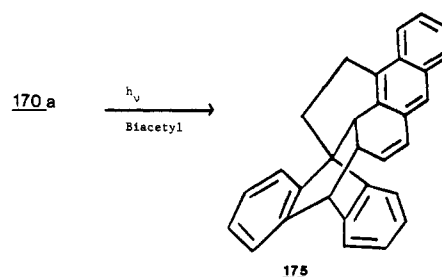

This difference in multiplicity apparently has some generality and has been observed with some substituted derivatives of 175.²⁶⁰ Thus, irradiation of 1,2-di(9-anthryl)ethanone (176), 0.01 M in benzene, gives mainly the $4\Pi_s + 4\Pi_s$ product 177.

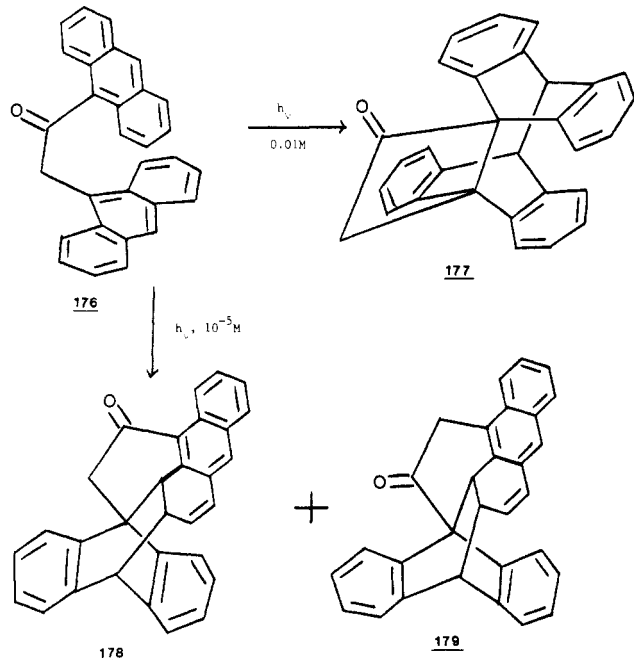

However, on irradiation in dilute solution (10^{-5} M), ketone 176 affords the isomeric $4\Pi_s + 2\Pi_s$ adducts 178 and 179.²⁶⁰ The triplet $4\Pi_s + 2\Pi_s$ products are formed inefficiently at high concentrations of 176 because of triplet quenching by ground-state 176. Quenching of anthracene triplets by ground-state anthracene had been described previously.²⁶¹

In some 9-anthryl-substituted ethylenes (e.g., 180a,b), the chromophores are not completely conjugated with the ethylenic bond because of deviations from planarity.²⁶² This affects the photochemistry, and on irra-

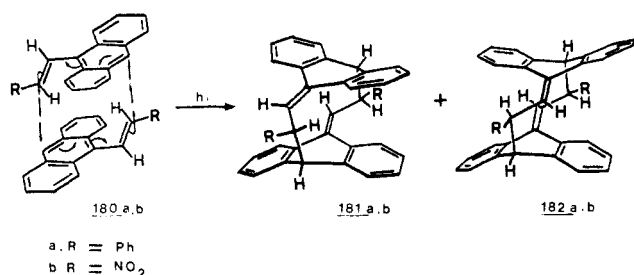

diation *trans*-(9-anthryl)-2-phenylethylene (180a) forms a negligible amount of the *cis* isomer.²⁶²

The major reaction is photodimerization. Thus, irradiation of 180a in benzene gives a 4 + 2 dimer (at the styrene double bond), a 4 + 4 dimer, and two isomeric 6 + 6 dimers (180a and 182a).

Irradiation of nitrovinylanthracene (180b) gives the 4 + 2 adduct and 6 + 6 adducts 181b and 182b but no 4 + 4 adduct.

Photodimerization of distyrylbenzene derivatives has

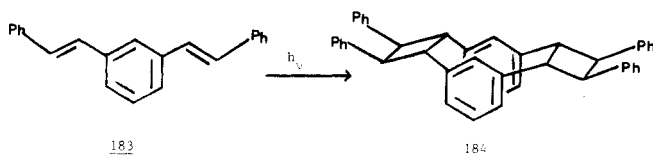

been used to obtain [2.2]cyclophanes. Thus, irradiation of 1,3-distyrylbenzene (183) in benzene gives three diastereomers of cyclophane 184.²⁶³

Internal photoaddition of linked phenanthrene and anisyl groups shows how linking can affect the reaction pathway.^{229a} Irradiation of the ester 185 in benzene gives the cyclobutane lactone 186a (15%) and the bicyclic acetal 186b (65%).

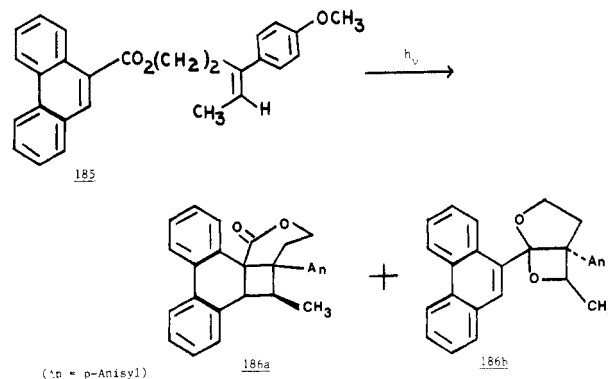

Irradiation of methyl 9-phenanthrenecarboxylate and *trans*-anethole gives only cyclobutane of the expected regiochemistry, but no carbonyl addition (i.e., acetal formation).^{229a}

Triplet-sensitized irradiation of allylindenes affords strained polycyclic systems via intramolecular $2\Pi + 2\Pi$ addition.²⁶⁴ For example, indene 187, in which the alkene units are linked with a two-carbon chain, forms 188 on sensitization with thioxanthone. The cyclo-

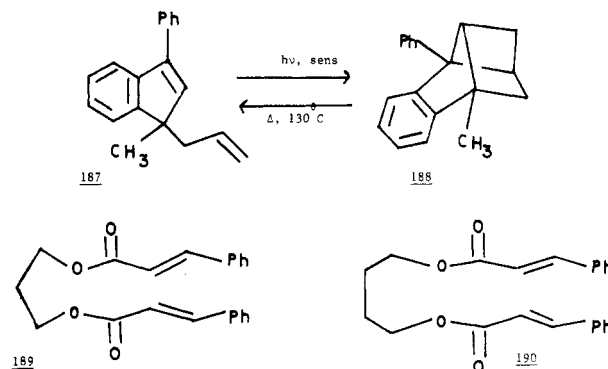

addition is thermally reversible, 188 forming indene 187 with a half-life of 10 h at 130 °C.²⁶⁴ Cycloaddition occurs with longer chains but is accompanied by hydrogen-transfer processes.²⁶⁴

Some work has been done on the cyclization of bi-chromophores with very long chains.^{225a,265-267} α,ω -Di-cinnamates such as 189 and 190 cyclize on sensitized irradiation, forming esters of the truxinic acids.²⁶⁵

In solution, 189 gives a mixture of the internal esters of β -truxinic acid and δ -truxinic acid (10%), while 190 gives the diester of δ -truxinic acid exclusively (cf. structures 25 and 26). The cyclization of cinnamate esters occurs with much longer chains (up to 35 bonds in the linking chain), but with lower quantum efficiencies.²⁶⁵

The photophysical and photochemical effects of linking two anthracene units with long alkane or polyether chains have been studied.^{225,227,266,267} Fluorescence and intramolecular dimerization quantum yield measurements and kinetic analysis were performed²⁶⁷ for a series of α,ω -di(9-anthryl)-*n*-alkanes (ethane to de-

cane). The excimer fluorescence yields and rate constants for excimer collapse to dimer did not show a regular dependence on chain length. Interestingly, no excimer fluorescence from 1,3-di(9-anthryl)propane was detected. Since there is little doubt that excimer would form in this case, the chain must be affecting the radiative decay constant or other decay processes of the excimer. Dimer formation quantum yield was 0.16, which does not account for the lack of fluorescence from the excimer.

Irradiation of bianthracenes linked by polyether chains gives macrocyclic ethers called "photocrowns".^{227,266} For example, **191** affords the macrocyclic internal dimer **192**. These macrocycles are

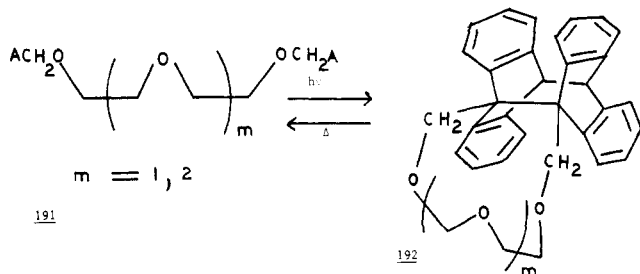

thermally more stable than those in which the anthracene units are linked directly to ether oxygens. Like the crown ethers, these "photocrowns" form complexes with metal cations. The macrocyclic ring is stabilized by complexing, and the complexes with lithium perchlorate have well-defined melting points.²⁶⁶

VI. Excited-State Electron Transfer

A. Reactions of Radical Ions and Ion Pairs

Some physical aspects of electron transfer are discussed in section II.D. The radical ions and ion pairs formed by excited-state electron transfer between organic molecules can lead to a number of chemical reactions, some of which are fairly general. These include cycloadditions, retroadditions, and reactions with solvent. Some of these reactions are described in this section and, in many cases, proposed mechanisms are also described. Electron-donor molecules include aryl and vinyl ethers, arenes, and amino compounds; commonly used acceptors are aryl nitriles, amides, esters, and quinones.

1. Reactions Involving Solvent

As noted in an earlier section (see eq. 38), electron transfer competes with exciplex formation in polar solvents. Just as exciplex fluorescence is quenched in polar solvents, chemical reactions involving the exciplex give way to reactions of ions and ion pairs.

For example, photoaddition of 2-naphthonitrile and tetramethylethylene (TME) in benzene affords cyclobutane **193** (cf. **63**), but in methanol the solvent-incorporated products **194** and **195** and dihydronaphthonitrile (**196**) are formed.^{5,6}

Although exciplex fluorescence was not observed from 2-naphthonitrile and TME in any solvent used, an ex-

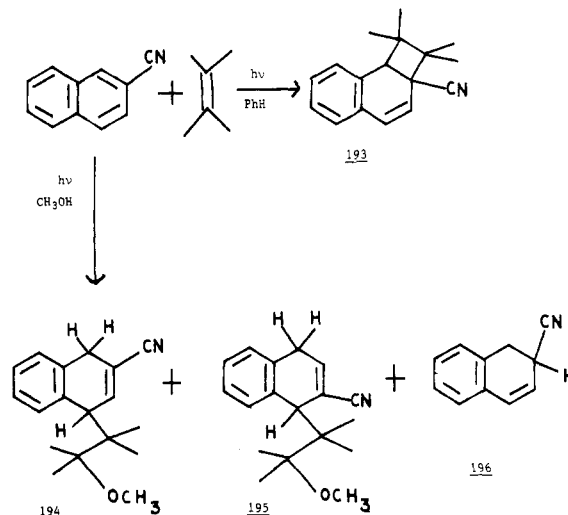

ciplex intermediate (nonemitting) was proposed.²⁶⁸ Cyclobutane **193** is similar to the cycloadducts from 1-naphthonitriles and TME (e.g., **61**, **63**, and **134**), and limiting quantum yields for formation of **63** and **193** are similar (0.14 and 0.21, respectively, for benzene solution), which suggests similar intermediates in the two reactions.²⁶⁸

Similar products (**197**–**199**) are obtained on irradiation of 9-cyanophenanthrene and tetramethylethylene^{269,270} in methanol, although the yield of cy-

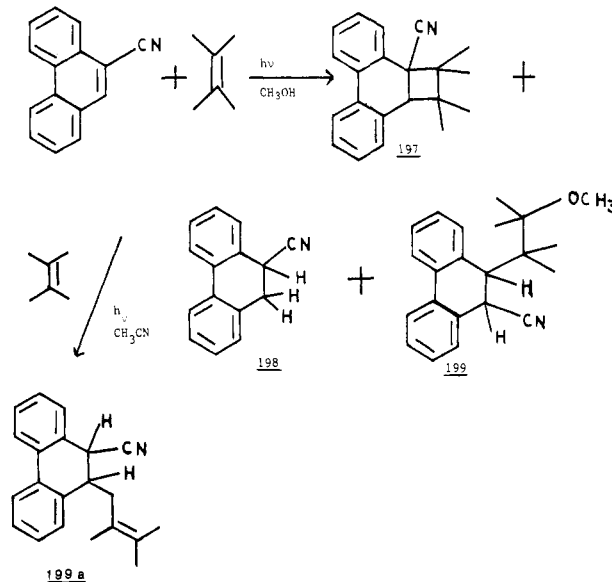

clobutane is significant and that of dihydronaphthalene is 50%. In acetonitrile, the dihydronaphthalene **199a** is formed.²⁶⁹

In benzene or ethyl acetate, photoaddition gives cycloadduct **197** as the exclusive product, with a limiting quantum yield (benzene) of 0.19.

Similar reactions are observed on irradiation of *trans*- α -phenylcinnamionitrile and 2,5-dimethyl-2,4-hexadiene.²⁷¹ In nonpolar solvents (hexane, ether), all four possible isomeric 2 + 2 cycloadducts are formed (**200**–**203**), and the reaction occurs via a singlet exciplex.

Irradiation of *trans*- α -phenylcinnamionitrile and 2,5-dimethyl-2,4-hexadiene in acetonitrile or methanol also leads to the formation of cycloadducts. In addition, the

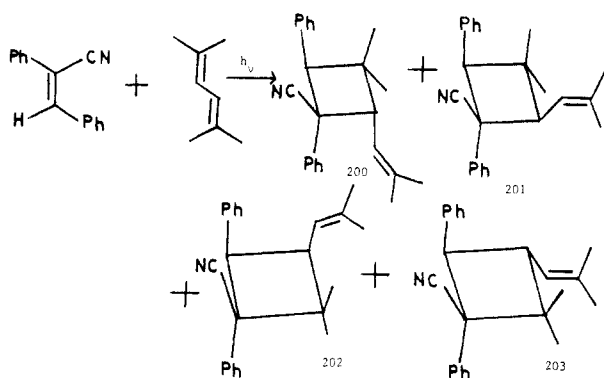

acyclic adducts **204** and **205** are formed in acetonitrile and methanol, respectively. The diether **206** and 2,3-

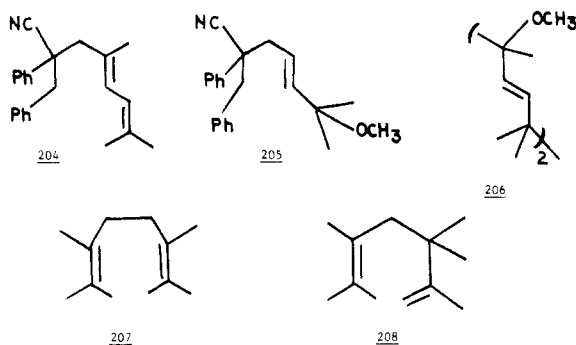

diphenylpropionitrile are also formed in methanol solution.²⁷¹ The same diether (**206**) was also isolated from 9-cyanophenanthrene and 2,5-dimethyl-2,4-hexadiene,²⁷⁰ while 9-cyanophenanthrene and TME gave **207** and **208** on irradiation in methanol.²⁶⁹ These reactions in polar solvents were, in general, inefficient ($\Phi \approx 10^{-3}$).

There is little doubt that these reactions result from excited-state electron transfer, which calculation shows is spontaneous. For 2-naphthonitrile-tetramethylethylene in polar solvents, ΔG (ion pair) has a calculated value of -1.8 kcal/mol.²⁶⁸ Formation of **194**–**196** can be represented as follows:

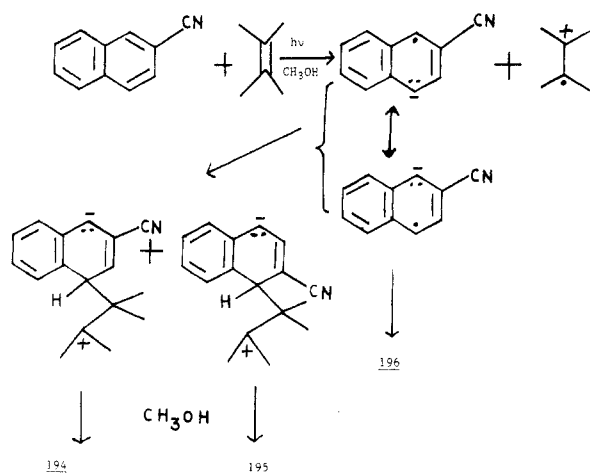

All the products can be explained, in a general way, as resulting from the processes shown in Scheme II. For example, reaction of the ion pair with solvent (methanol) would give **194** and **195**, while dihydronaphthalene (**196**) and dimers such as **207** and **208** would result from reactions of the separate ions. The timing of the various steps may not be as shown above. Lewis²⁶⁹ has argued that formation of **199** does not involve a zwitterion but

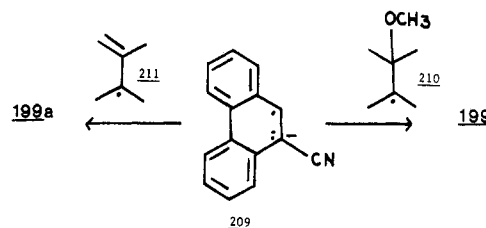

results from coupling of the radical anion of 9-cyanophenanthrene (**209**) and the methoxy-substituted radical **210**. Deprotonation of the TME radical cation in acetonitrile gives **199a** via coupling of the allylic radical **211** with radical anion **209**.

Reactions of the naphthonitriles with TME in polar solvents have not been studied quantitatively, but Lewis and DeVoe²⁶⁹ found that reaction of 9-cyanophenanthrene and TME was complex, depending on solvent polarity, methanol concentration, methanol deuteration, and light intensity. It is likely that the mechanistic detail depends on the reactants involved.

Deprotonation of the TME radical cation in acetonitrile is one of a number of proton-transfer reactions resulting from excited-state charge separation. Some of the reactions occur in polar or nonpolar media, while others require polar solvents. The proton source can be allylic or benzylic C–H groups, N–H groups, or solvent (alcohol) O–H groups. Examples include the reactions of indene and naphthalene with acrylonitrile,³ of 2-methyl-1-naphthonitrile¹⁴ and benzene¹⁵⁹ with TME, of aryl dinitriles with TME and with methyl arenes,^{272,273} and of arenes with amines²⁷⁴ and heterocyclic compounds. The latter are described in section VII. The field has been reviewed.²⁷²

The first of these reactions to be described was substitution at the benzylic C–H bonds of indene, which occurs on irradiation of indene and acrylonitrile.³ We proposed that the reaction (formation of **115a**) involved electron transfer followed by proton transfer and radical coupling.

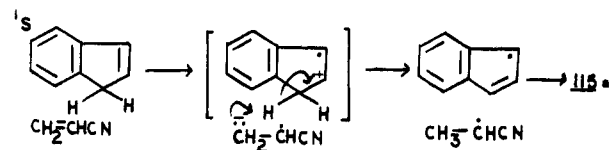

This reaction occurs readily in polar or nonpolar solvents, indicating that an exciplex and/or solvated ion pair can be involved. This contrasts with the related naphthalene-acrylonitrile reaction, which requires hydroxylic solvents that also act as a proton source.³ Indenes lacking the benzylic hydrogens (e.g., 1,1-dimethylindene) gave no substitution products on irradiation with acrylonitrile.

Much more is known about the factors affecting this reaction than was the case when we discovered it approximately 20 years ago. The energetics of electron transfer and the kinetics of proton transfer are both important. Results from picosecond spectroscopy²⁷⁵ and relevant data on radical ions²⁷⁶ are now available.

Apparently, highly delocalized (stable) acceptors or donors undergo proton-transfer reactions less readily, owing to their low kinetic basicity or acidity.²⁷³ This provides a satisfactory explanation of the frequent failure to observe substitution products (corresponding to **59**, **60**, and **115a**) when better electron acceptors (e.g.,

fumaronitrile) are used in these additions.

Reactions have been observed on irradiation of aryl dinitriles with TME or methylarenes in acetonitrile.^{272,273} These reactions involve electron transfer, proton transfer, and radical coupling. In some cases substitution of a nitrile substituent occurs. Examples are shown below.

The structures of 212–214 were determined by X-ray

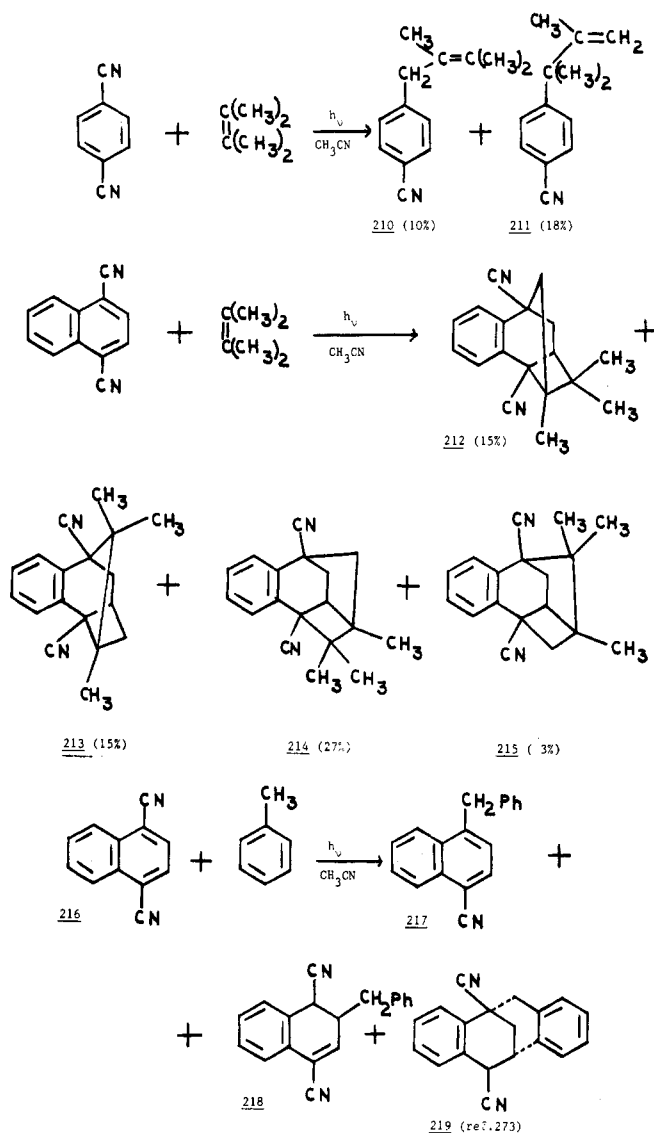

crystallographic analysis.²⁷² The products were not formed in apolar solvents, in which exciplex fluorescence was observed.²⁷³

The detailed mechanism of these reactions has been investigated.^{272,273} Formation of 210 and 211, for example, is proposed to involve electron transfer and proton transfer to give a pair of radicals (220), which can combine in two ways giving 221 and 222. The latter give the aromatized products 210 and 211 on loss of HCN. A similar sequence can lead to 223 and 224, which on photocyclization give the products 212–215.

Formation of 217 and 218 from 1,4-naphthalenedicarbonitrile (216) and toluene can follow a similar pathway.²⁷³ Electron transfer, proton transfer, and coupling of the radical pair (one of which is the benzylic radical) can clearly give 217 and 218.

Attention has been focused on the tetracyclic product

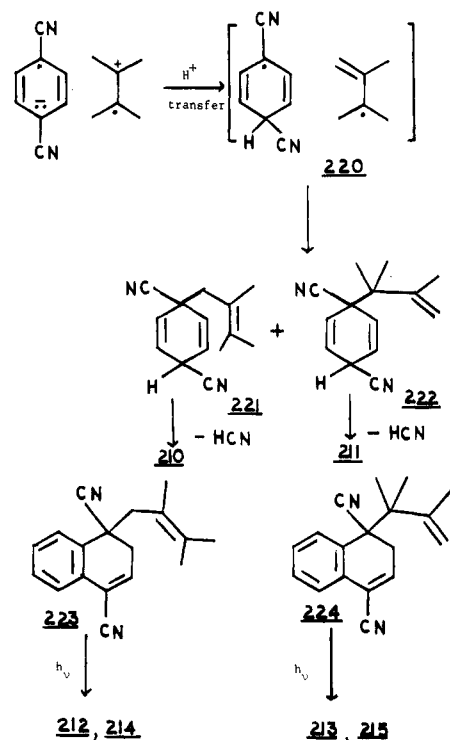

219.^{273b} It is apparently a primary product and is not formed from 225—a possible precursor.

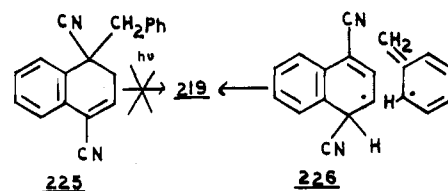

Coupling of the radical pair 226 followed by a (second) hydrogen shift can indeed rationalize the tetracyclic product. Because of the stereospecific pathway to 219, a concerted $3\text{II} + 3\text{II}$ coupling of the radical pair 226 was considered.^{273b} In both hydrogen shifts involved in formation of 219, water apparently plays a catalytic role.^{273b}

The above reactions in which a nitrile substituent is “displaced” seem to occur when the donor–acceptor properties of the reactants are particularly marked.^{272,273b} The reaction was first observed with tetracyanoethylene and methylarenes.²⁷⁷ Other examples include the reaction of 9,10-dicyanoanthracene with amines²⁷⁸ and of 1,4-dicyanonaphthalene with tetracoordinated borates.²⁷⁹ Interestingly, displacement of a nitrile substituent in tetracyanoethylene by aromatic amines occurs in a ground-state reaction via the charge-transfer complex.²⁸⁰

2. Cyclobutane-Forming Additions

Electron-rich aromatic olefins such as *N*-vinylcarbazole, indenenes, styrenes, and vinyl ethers form cyclobutane dimers on irradiation in the presence of an electron acceptor.^{281,286} Cycloaddition involves the relatively stable olefin radical cations, and major products are usually the trans head-to-head cyclobutanes. Widely used electron acceptors are 1,4-dicyanobenzene, 1,4-dicyanonaphthalene, and 9,10-dicyanoanthracene. Irradiation of phenyl vinyl ether in

polar solvents using 9,10-dicyanoanthracene (DCA) as electron acceptor gives the head-to-head cyclobutanes **227** and **228**.²⁸² Interestingly, alkyl vinyl ethers do not

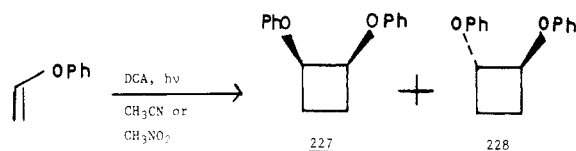

dimerize in this reaction, but will form "mixed" dimers in the presence of an aryl vinyl ether.²⁸² Alkyl, benzyl, and trimethylsilyl vinyl ethers have, however, been reported to dimerize when 1,4-dicyanonaphthalene rather than DCA is used as sensitizer.²⁸³

The photochemical electron-transfer reactions of 1,1-diarylethylenes, sensitized by cyanoanthracenes, have been studied.²⁸⁴ 1,1-Diphenylethylene (**229**) yields 2 +

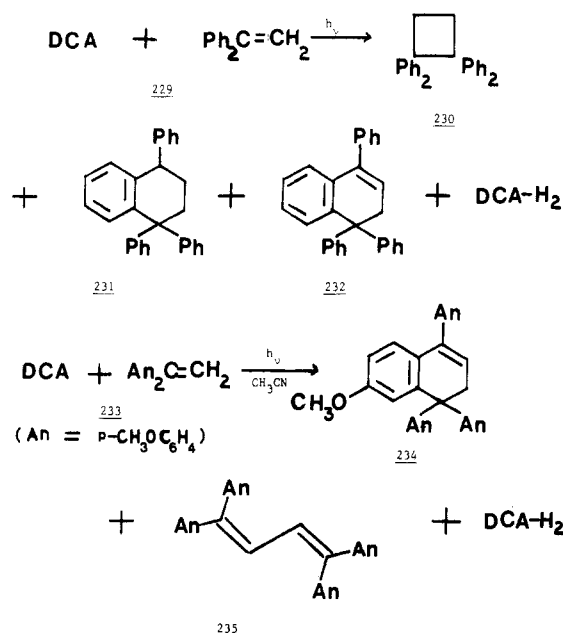

2 and 2 + 4 dimers (**230** and **231**) and dehydrodimer **232**. Reduction of the sensitizer (9,10-dicyanoanthracene) to the 9,10-dihydro derivative also occurs. 1,1-Dianisylethylene (**233**) gives two dehydrodimers (**234** and **235**), but 1,1-bis(4-dimethylaminophenyl)ethylene (**236**) forms no dimers. The reactions are summarized below.

Cyclobutane adducts **227** and **230** were found to be thermally unstable at room temperature.^{284,285} The mechanism for their formation is shown in eq 66–69.

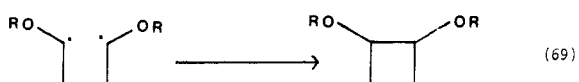
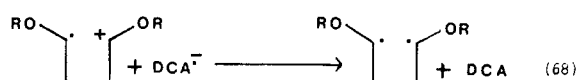
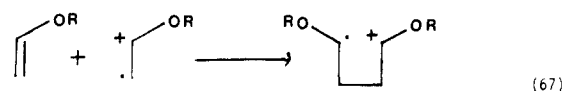
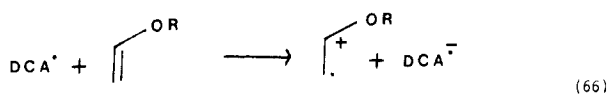

In some cases, the electron that comes from the radical anion DCA in eq 68 is donated by a third molecule of olefin, and a chain mechanism results.²⁸¹

In some schemes, cyclization of the open-chain radical cation, giving the cyclobutane radical cation, is proposed,^{281,282} without the intervention of a neutral biradical. In my opinion, eq 68 and 69 are a more reasonable pathway to the cycloadducts since they avoid the unstable cyclobutane radical cation. In this regard, nuclear polarization studies (CIDNP) indicate that the radical cations derived from norbornadiene and quadricyclane have structures **237** and **238**, respectively, and no evidence for delocalized structure (**239**) was obtained.²⁸⁷

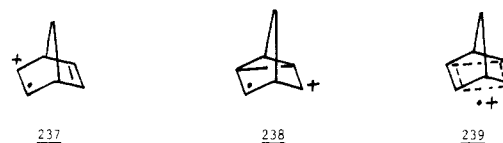

Interestingly, a case has been reported in which electron transfer prevents cyclobutane formation.²⁸⁶ In nonpolar solvents, irradiation of 4-(dimethylamino)styrene (donor) with either 1-vinylpyrene or styrene as electron acceptors gave the mixed cyclobutane adducts. Transient absorption of an exciplex was observed in benzene solvent. The yield of cyclobutanes decreased with increasing solvent polarity, and in acetonitrile copolymer was the major product. Transient absorption in acetonitrile was ascribed to cation and anion radicals. The stabilized 4-(dimethylamino)styrene radical cation apparently has little tendency to cyclize. This is consistent with the lack of reactivity of bis(4-dimethylaminophenyl)ethylene (**236**),²⁸⁴ which also forms no dimers. 1,1-Dianisylethylene (**233**) is somewhat more reactive, forming dimers **234** and **235**.

Tetralin derivatives related to **231**–**234** are also formed on electron-transfer sensitization of styrene, α -methylstyrene, and *m*-methoxystyrene.²⁸⁸ The open-chain, dimeric radical cations cyclize, forming a six-membered ring. The sequence is shown for *m*-methoxystyrene, which forms **241** and **242** via the in-

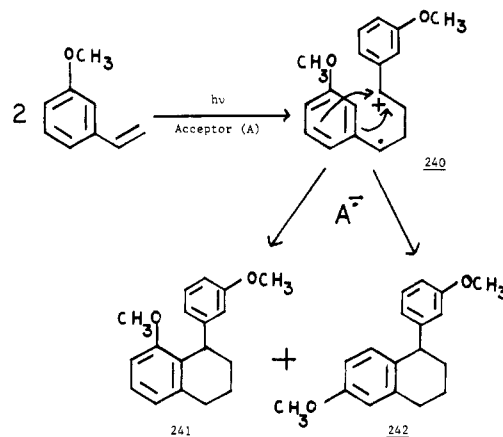

intermediate cation **240** on sensitization with *m*-dicyanobenzene in various solvents.²⁸⁸

In a similar type of reaction, phenylacetylene forms 1-phenylnaphthalene on irradiation with tetracyanoanthracene as electron acceptor.²⁸⁹ Products of reaction with solvent (CH_3CN , CH_3NO_2) are also formed.²⁸⁹

The acyclic diene **235** is also a logical product of the

open-chain, dimeric radical cations. Proton loss from **240** and further oxidation would give a diene. Such products (e.g., **235**) are well-known in the electrochemical oxidation of styrenes.²⁹⁰

Formation of dimer **231** has been reported on dimerization of 1,1-diphenylethylene in acetonitrile using methyl *p*-cyanobenzoate as sensitizer. A minor amount of oxetane **243** is also formed. This oxetane is the major product when the reaction is carried out in benzene.^{61d}

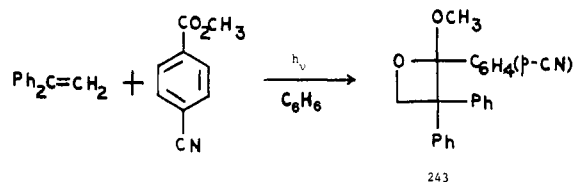

Indene derivatives form cyclobutane dimers on irradiation with electron-accepting sensitizers.^{61d,291} Thus, irradiation of 1,1-dimethylindene and 2,4,6-triphenylpyrylium salts in acetonitrile leads to good yields of the anti head-to-head dimer (cf. 16). Formation of anti head-to-head dimers is consistent with the intermediacy of the indene radical cation. Dimers with the tetralin structure (e.g., **231** and **241**) would not be expected from indenenes.

3. Bond-Cleavage Reactions and Retroadditions

Bond-cleavage reactions, often leading to retroadditions, can result from electron transfer of cycloadducts. Examples include simple²⁹² and fused²⁹³ cyclobutanes, cage compounds,^{294,295} and 4 + 4 dimers of anthracene derivatives.^{296,297} Some illustrative examples (**244**–**256**) are shown below.

In some cases there is good evidence for the open-chain radical cation as intermediate (cf. eq 56). For example, *cis*-1,2-diphenylcyclobutane (**244**) yields the *trans* isomer **245**, as well as styrene, on sensitization with DCA in acetonitrile.²⁹² This implies that an intermediate which can cyclize, or fragment, is formed. The mode of cyclization depends on the reaction conditions, since 1-phenyltetralin is formed in benzene solvent.²⁹²

Stereochemistry can affect the ring-cleavage reaction. On electron-transfer sensitization of the *cis*-fused cyclobutane **246**, cleavage occurs in mode a, forming phenanthrene and *trans*-stilbene, while the *trans*-fused isomer **247** gives distyrylbiphenyl (**248**),²⁹³ resulting from mode b fragmentation.

Strained cyclobutanes undergo cycloreversion when the radical cation is formed.^{294,295} The phenylated cage compounds **249** form the corresponding dienes **250** on treatment with ground-state oxidizing agents, on electron transfer to an excited acceptor molecule, or on irradiation of the charge-transfer band of complexes with some acceptors. When tetracyanoethylene is used as electron acceptor, the diene adds a molecule of tetracyanoethylene, forming **251**. In the absence of electron acceptors, **250** undergoes internal cycloaddition, forming **249** on irradiation.

The 4II + 4II dimer **252** of the acridizinium ion cleaves on electron transfer from excited dye molecules (e.g., erythrosin), forming the monomeric acridizinium ion (**253**).²⁹⁶ The 4II + 4II dimer of anthracene cleaves in a similar way on sensitization with chloranil or

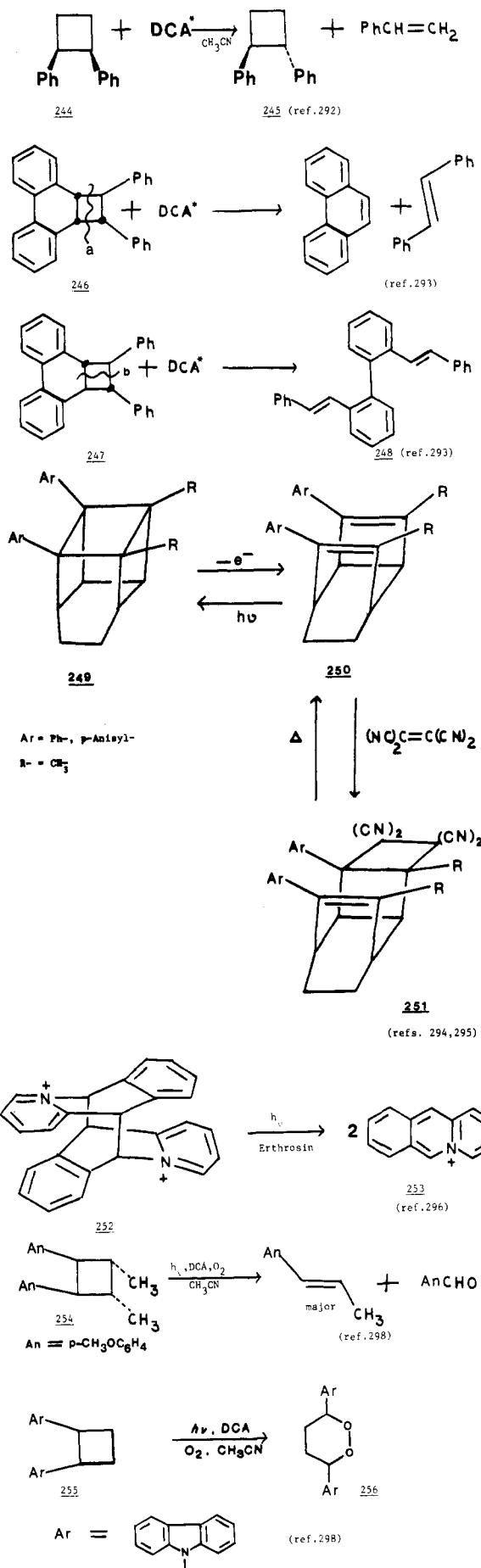

9,10-dicyanoanthracene, forming anthracene, and a radical cation mechanism was proposed.²⁹⁷

Cyclobutane ring cleavage sometimes competes with electron-transfer-sensitized oxygenation.²⁹⁸ For example, irradiation of the dianisylcyclobutane (**254**) with DCA in the presence of oxygen gives *trans*-1-anisylpropene (*trans*-anethole) as major product, with just minor amounts of oxidation product anisaldehyde.²⁹⁸ Irradiation of *trans*-1,2-(*N*-carbazolyl)cyclobutane (**255**) under the same conditions gives the 1,2-dioxane **256** in 60–70% yield. In this case interception of the open-chain radical cation derived from **255** leads to the oxygenated product.

4. Cosensitized Electron Transfer

A number of reactions are known in which the rate and yield of product can be increased by use of a chemically unreactive aromatic hydrocarbon in conjunction with an electron-deficient photosensitizer.^{291,299–302} This is called cosensitization and has been used with dimerizations,^{291,299} photooxygenations,^{300,301} and acetal-exchange reactions.³⁰² Phenanthrene and biphenyl have been used as cosensitizers, in conjunction with aryl dinitriles, e.g., DCA, as electron acceptors.

For example, the dimerization of indene has been cosensitized by using phenanthrene (light absorber) in conjunction with *p*-dicyanobenzene. The steps involved are shown in eq 70–74, where Phen = phenanthrene, Ind = indene, and (Ind)₂ is indene dimer 16.

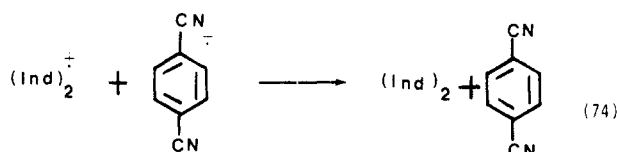
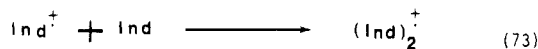
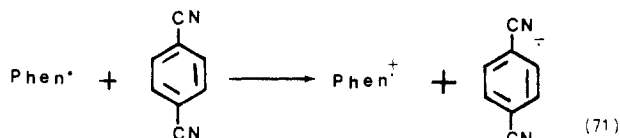
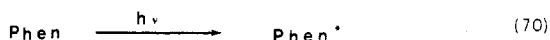

Cosensitization of cyclobutane formation was first observed in the dimerization of phenyl vinyl ether.²⁹¹ The quantum yield of formation of dimer **227** was increased up to 200 times if 9-cyanoanthracene plus a cosensitizer (phenanthrene, methylnaphthalenes) was used, rather than 9-cyanoanthracene alone.

Dramatic rate increases on cosensitization of oxy-

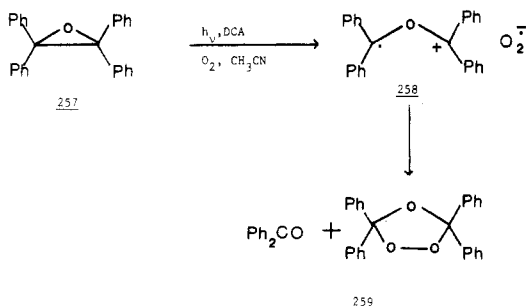

genation reactions have been observed.^{300,301} Photooxygenation of tetraphenylloxirane (**257**) using DCA in acetonitrile gives the ozonide **259** in 64% yield. The reaction proceeds via the ion pair **258**.

With just DCA as sensitizer the reaction is slow. On addition of biphenyl as cosensitizer, rate increases by factors of 20–120 are observed, depending on the biphenyl concentration.³⁰⁰

Reasons for the effectiveness of cosensitization have been discussed.³⁰¹ In some cases, e.g., the tetraphenylloxirane–DCA system described above, the substrate is an inefficient quencher of the sensitizer excited state (¹DCA*).³⁰⁰ Therefore, formation of the oxirane radical cation via reaction 75 is inefficient. However,

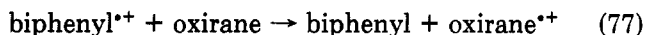

biphenyl is an efficient quencher of ¹DCA*, and formation of the oxirane radical cation via reactions 76 and 77 proceeds well. This is because of the longer lifetime of biphenyl radical cation compared with that of ¹DCA*. A similar explanation was proposed for the cosensitized dimerization of phenyl vinyl ether.³⁰¹

In other cases, cosensitization by biphenyl may provide rate increases even when the substrates are better quenchers of ¹DCA* than biphenyl. An example is the photooxygenation of 1,1,2,2-tetraphenylcyclopropane, which is a better quencher of ¹DCA* than biphenyl, yet the rate of photooxygenation is increased by a factor of 10 by using biphenyl as cosensitizer.³⁰¹ The reason given is that the yield of free ions (Scheme II) increases as the exothermicity for back electron transfer (*k*_{be}) increases over the range 2.1–2.8 eV.³⁰¹ These considerations suggest that the most effective cosensitizers for DCA should be those with oxidation potentials of 1.8–2.0 V. These will be effective quenchers of ¹DCA* and should also give a high yield of free ions resulting from electron transfer.

5. Photochemistry of Iminium Salts

The use of *N*-alkylpyridinium salts, particularly *p*,*p*'-bipyridyl or "paraquat" derivatives as electron acceptors is well-known.^{62a} The related iminium salts also participate in excited state electron transfer processes, which can lead to photochemical reactions. This area has been reviewed.³⁰³

On electron transfer from a donor (D) to an excited iminium ion, the latter becomes a neutral radical (eq 78). This radical (**260**) has free radical character at the

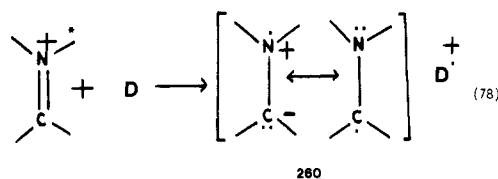

α -carbon and can couple with free radical species such as D^{•+}. This is equivalent to nucleophilic addition of D to the iminium ion, but it occurs in two one-electron steps. Donors with low enough oxidation potentials to react include alcohols, ethers, and various alkenes.³⁰³

Some of these reactions are useful in the construction of polycyclic ring systems containing nitrogen, examples of which (261–267) are shown below.

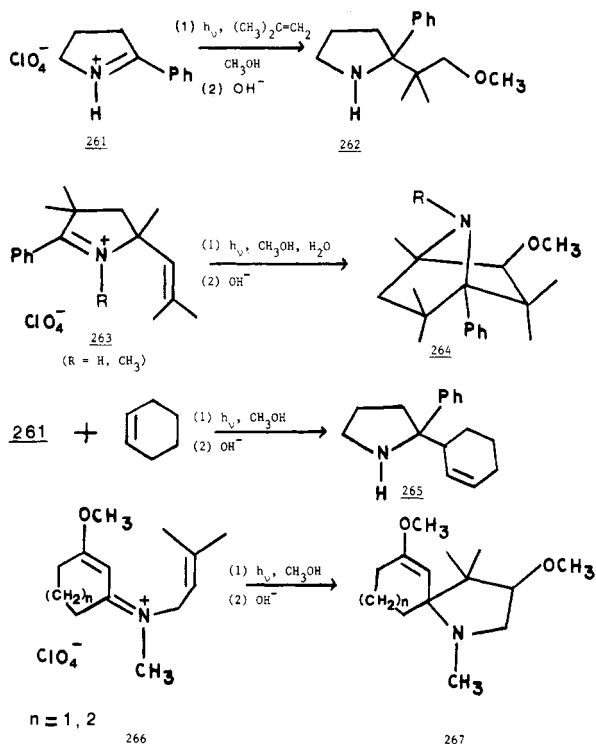

The mechanism of these reactions follows quite logically from the initial electron transfer shown in eq 78. Thus, the radical pair 268 formed from 261 and isobutylene reacts as follows:

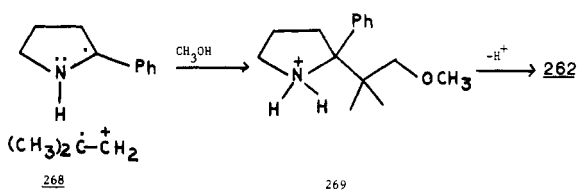

The reactions of 263 and 266 are intramolecular equivalents of the reaction of 261 with isobutylene, but formation of 265 from 261 and cyclohexene involves a proton-transfer step after the initial electron transfer.³⁰³

The above reactions occur when electron-rich alkenes are used. When alkene derivatives with electron-withdrawing groups are employed, a cyclobutane ring is formed by $2\Pi + 2\Pi$ cycloaddition to the phenyl group of 261. The cycloadduct (e.g., 270) undergoes ring

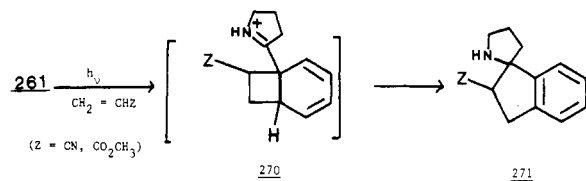

expansion, forming the spiro compound 271. This reaction is also potentially useful in synthetic work.

VII. Photoadditions of Heterocyclic Compounds

Heterocyclic compounds undergo some of the photochemical reactions already described for carbocyclic systems, including additions, electron transfer, and

rearrangements. In this section some photoadditions of heterocyclic compounds are described. Reviews of the field are available.^{304,305} In the present discussion, biological molecules such as nucleic acids have been omitted, since their photochemistry is a large and separate area.

A. Pyrrole and Indole Derivatives

At one time it was thought that these heterocycles were fairly inert to photoadditions, but several such reactions of the compounds are now known.

Naphthalene reacts with pyrrole on irradiation, forming dihydronaphthalenes 272 and 273.³⁰⁶ Benzene

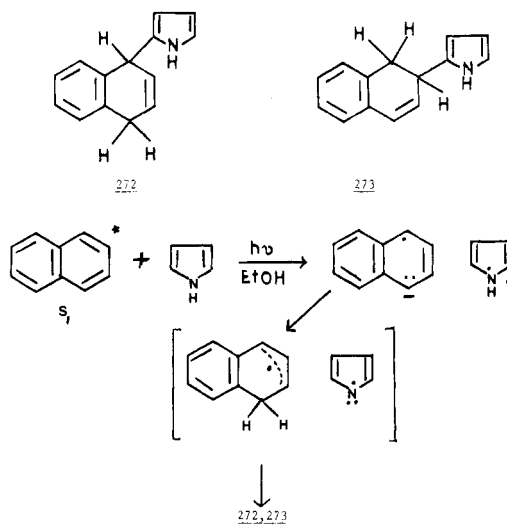

and pyrrole react similarly,³⁰⁷ but *N*-methylpyrrole fails to react, although pyrrole and *N*-methylpyrrole quench the naphthalene fluorescence with similar efficiencies. A mechanism was proposed in which excited-state electron transfer, followed by proton transfer, leads to products.

Other mechanisms are possible and, since the reaction proceeds well in nonpolar solvents,³⁰⁶ exciplexes could be involved.

Similar reactions involving proton transfer occur on irradiation of indole and imidazole derivatives with acrylonitrile,^{308,309} reactions which resemble the indene-acrylonitrile addition.¹⁶⁶ For example, indoles that possess an N-H group react with acrylonitrile, forming compounds such as 274 on irradiation in methanol or acetonitrile.³⁰⁸ However, *N*-methylindoles only form these products in protic solvents like methanol. For example, 1,2-dimethylindole forms 275 and 276.³⁰⁸

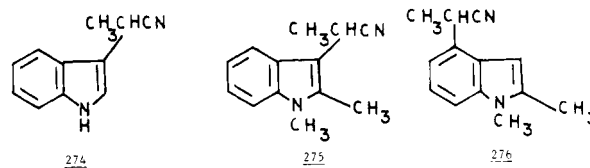

Similar chemistry is observed with imidazoles. Irradiation of 2,4,5-triphenylimidazole (277) and acrylonitrile in either ethanol or acetonitrile yields the α -cyanoethyl derivative 278.³⁰⁹ With *N*-methyl-2,4,5-triphenylimidazole (279) cycloaddition occurs, forming 280, in ethanol. In acetonitrile, reaction of 279 affords imidazolinone 281, via zwitterion 282, which is proposed

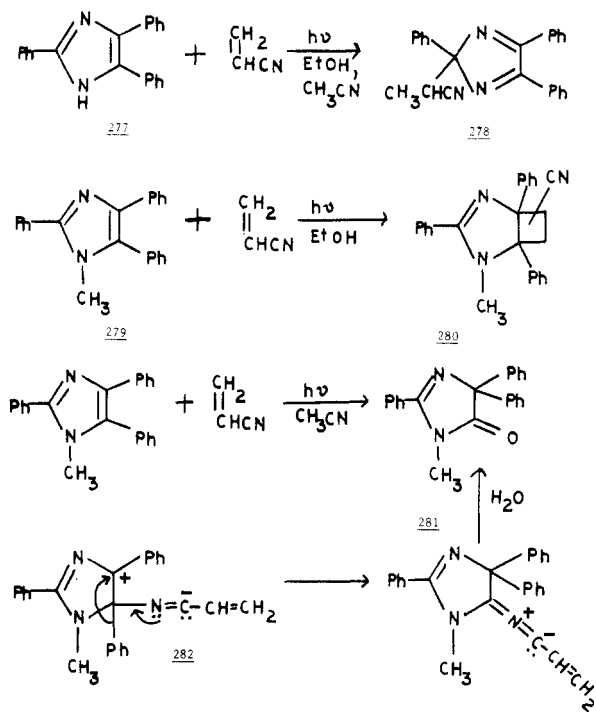

to result from coupling of an ion pair.³⁰⁹

Clearly, the photoreactions of pyrroles, indoles, and imidazoles (and indenenes) depend on the presence of ionizable protons (e.g., N-H groups) and on the electron-donating ability of the heterocyclic compound. However, if electron-withdrawing groups are introduced, the more usual type of photoaddition can be observed. Sensitized addition of *N*-acylindoles 283 to a variety of ethylenes gives cyclobutane adducts 284 in good yield.³¹⁰

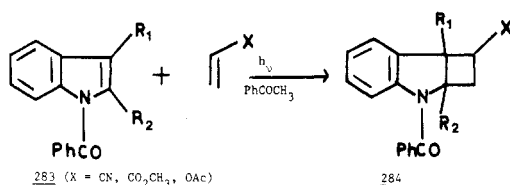

A range of substituents R^1 and R^2 were employed, and some of the adducts were converted into compounds of pharmacological interest.³¹⁰

Photoadditions of various methylindoles with di-

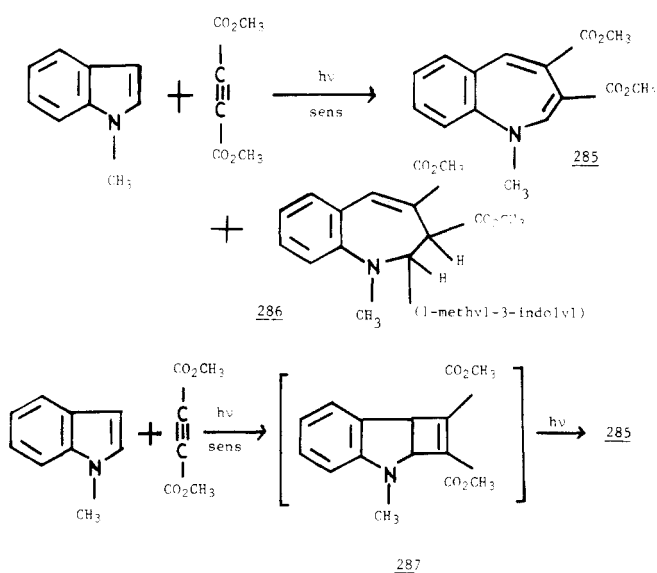

methylacetylene dicarboxylate (DMAD) have been reported.^{311,312} Irradiation of *N*-methylpyrrole and DMAD affords benzazepine (285) and a substituted derivative (286), attributed to secondary reactions.³¹¹ It was proposed that 285 was formed by photochemical, disrotatory ring opening of cyclobutene 287.

It was indeed found that in systems where this ring-opening reaction was geometrically constrained the cyclobutene could be isolated.³¹¹ The bridged indole 288 reacted with DMAD, forming cyclobutene 289.

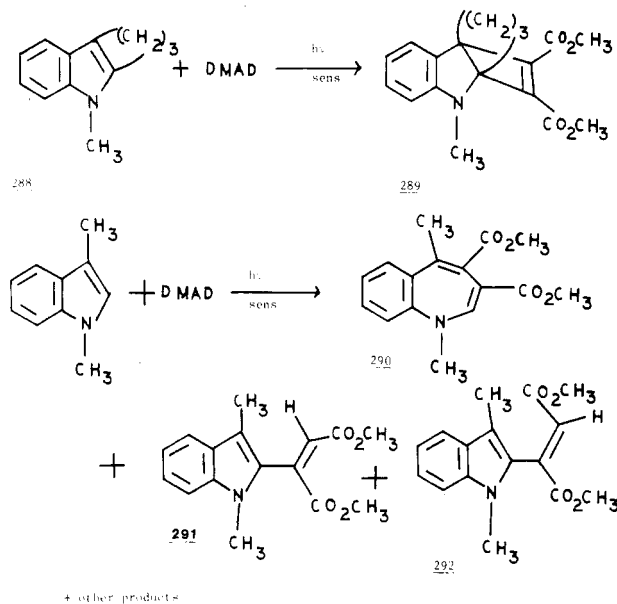

The latter had a deep red color (presumably a charge-transfer band due to the amino nitrogen and unsaturated ester groups) and did not undergo thermal or photochemical ring opening or other rearrangements. 1,3-Dimethylindole also reacted with DMAD, forming a number of products.³¹² These included benzazepine 290, and maleate and fumarate esters 291 and 292. The latter formation involves protonation by solvent (methanol) (cf. naphthalene and acrylonitrile, ref 3).

B. Pyridine and Quinoline Derivatives

Pyridine, quinoline, and isoquinoline are generally unreactive photochemically, particularly toward addition reactions. Quinoline and isoquinoline form fluorescent excimers in hydroxylic solvents at low temperatures,³¹³ and chemical reactions might be observed under suitable conditions. Certain derivatives of these heterocycles are, however, photochemically reactive.

2-Pyridone (293) forms the $4\pi + 4\pi$ dimer 294 on irradiation in concentrated solution,³¹⁴ while in dilute solution, the Dewar isomer azabicyclohexenone (295) is formed.³¹⁵

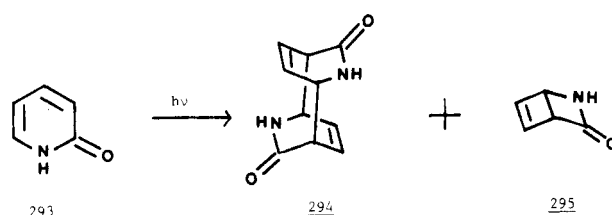

A number of pyridine derivatives such as the 2-amino-pyridinium ion and acridinium derivatives also form

4 Π + 4 Π dimers on irradiation.³¹⁶ A wide variety of six-membered-ring heterocycles form the Dewar isomers.^{317,318}

On the other hand, irradiation of 2-quinolone gives the cyclobutane dimer,³¹⁷ corresponding to the well-known dimer of coumarin (18). 2-Quinolones also give mixed 2 Π + 2 Π adducts on irradiation with ethylene derivatives.^{319,320}

Intermolecular photoaddition of 4-methoxy-2-quinolone (296) and allyl acetate gives cyclobutane 297 (mixture of epimers), which eliminates methanol on base treatment to form the cyclobutaquinolinone 298.³¹⁹

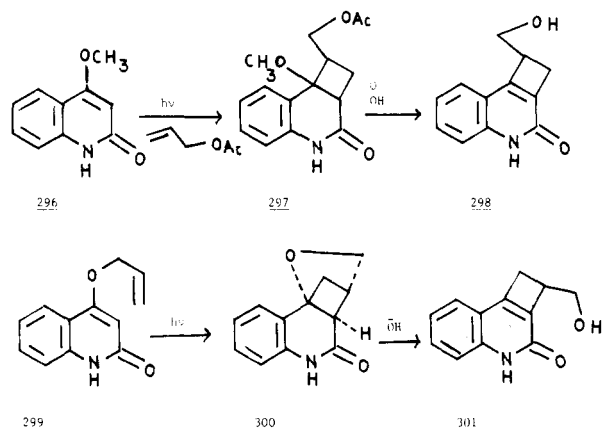

However, irradiation of the bichromophoric compound 4-allyloxy-2-quinolone (299) in methanol gives the tetracyclic compound 300 in 85% yield,³¹⁹ which on base treatment forms cyclobutaquinolinone 301. Thus, these inter- and intramolecular cycloadditions give different regioisomers. This is an interesting example of the directing power of a linking chain, of which synthetic chemists should take note.

Irradiation of bichromophoric compound 302, which has a 3-atom linking chain, affords both regioisomers 303 and 304, in ratio 7:1. Base treatment of 303 and

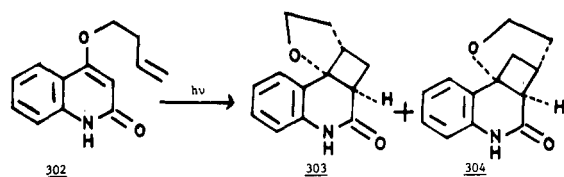

304 again affords the corresponding cyclobutaquinolones.³¹⁹

Intermolecular addition of 4-methoxy-2-quinolones and of 4-acetoxy-2-pyridones to allene gives methylene derivatives of 297 in reasonable yields.^{320a} The reaction is synthetically useful.

Interesting results have been reported with the 2-(alkenyl)isoquinolones (305).^{320b} Irradiation of these compounds (350 nm) gave the intramolecular (2 + 2) adducts 306 regioselectively. On irradiation at 300 nm these intramolecular adducts cleave, forming *o*-vinylbenzamides 307. The products of intermolecular addition of isoquinolin-1(2*H*)-one and various alkenes (308) cleave forming the isoquinolone and alkene on irradiation at 300 nm.^{320b}

Some halogen derivatives of pyridine undergo photoadditions with ethylene and other simple alkenes.^{321,322} Pentafluoropyridine reacts with ethylene on irradiation

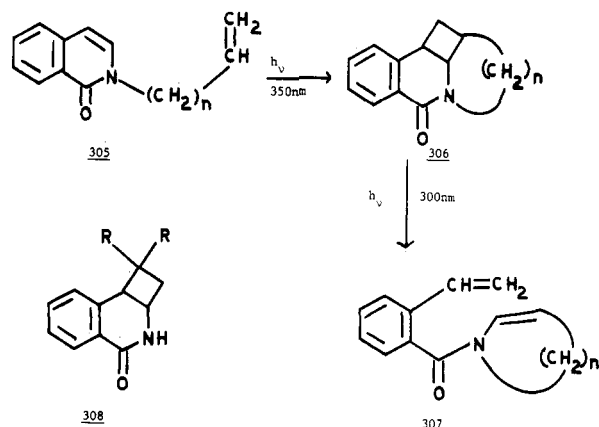

with light at wavelengths >200 nm to form a 1:1 cyclobutane adduct 309 and a 2:1 adduct 310.³²¹ The

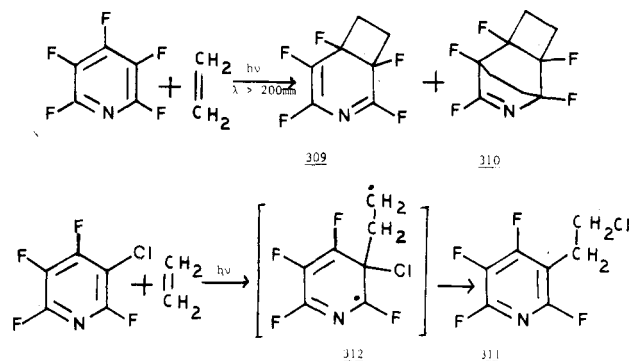

latter was formed from the cyclobutane adduct in a thermal addition, as shown by control experiments.

Hexafluorobenzene also reacts with indene, 1,2-dihydronaphthalene, and phenylacetylenes to form cyclobutane adducts on irradiation.¹³⁸ However, 3-chlorotetrafluoropyridine reacts with ethylene in a different way, forming substitution product 311 in high yield (77%).³²² No cycloadducts were observed.

A 1,3-chlorine atom migration in biradical intermediate 312 was proposed, and a similar intermediate may lead to cycloadduct 309.

Photosubstitution of cyano groups in cyanopyridines, quinolines, and pyrimidines also occurs.^{323,324} Irradiation of 4-cyanopyridine or 2-cyanoquinoline with tetramethylethylene gives 313 and 314 or 315 and 316, respectively, but no cycloadducts.³²³

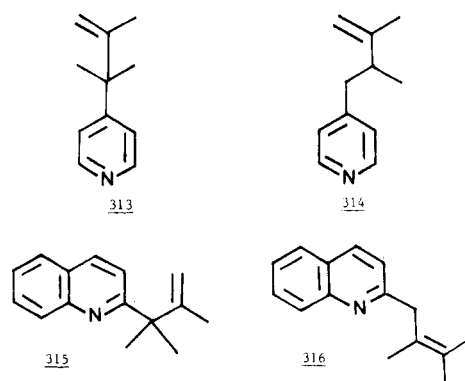

Suggested mechanisms for these substitutions include electron transfer or hydrogen abstraction from the olefin by the $n\pi^*$ state of the heterocyclic base.³²³

Interesting photochemistry has been observed in the

addition of 6-cyano-1,3-dimethyluracil (**317**) with 1-phenyl-1-propyne or with diphenylacetylene.³²⁴ Irradiation of **317** and 1-phenyl-1-propyne with a medium-

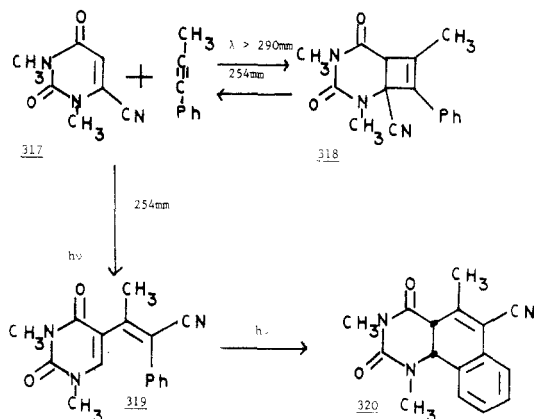

pressure mercury lamp and Pyrex filter gave cyclobutene adduct **318**, but with shorter wavelength light (254 nm) the 5-substituted uracil **319** was formed.

The latter underwent further photolysis, forming tricyclic compound **320**, whose structure was confirmed by X-ray analysis.³²⁴ The cycloadduct **318** was photolabile, decomposing to **317** and 1-phenylpropyne with 254-nm light. Formation of **319** may result from excitation of both **317** and the 1-phenylpropyne at 254 nm, and therefore several mechanisms are possible.

Uracil, thymine, and some methyl derivatives add to alkenes on sensitization with acetone.³²⁵ One example is the addition of 1,3-dimethyluracil (**321**) and iso-

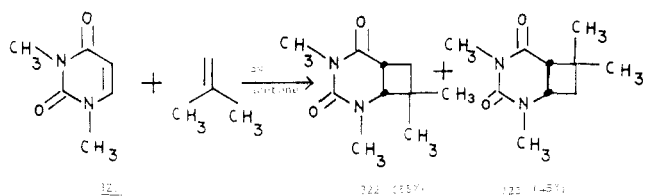

butylene, giving the two *cis*-fused cyclobutanes **322** and **323**.³²⁵ Products **322** and **323** are formed in approximately equal amounts, in 76% isolated yield.

The intermediacy of biradicals in the addition of isobutylene to uracil has been probed by using compounds **324** and **325**.³²⁶ It was found that the clo-

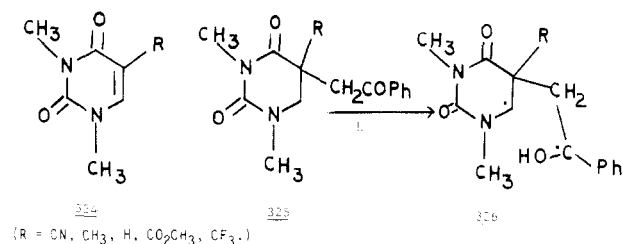

sure-to-cleavage ratios of biradical **326** (formed by photolysis of **325**) correlated with the regiochemistry of addition of isobutylene to the series of uracils **324**. The substituent effects on the biradical reactions seemed to be steric in origin, since the closure-to-cleavage ratios correlated with conformational *A* values of the substituents.³²⁶

C. Furan and Thiophene Derivatives

Sensitized photodimerization of benzofuran (**327**) gives the *syn*- and *anti*-cyclobutane dimers **328** and **329** in 1:3

ratio³²⁷ in a reaction similar to dimerization of indene, coumarin, and other styrene derivatives.

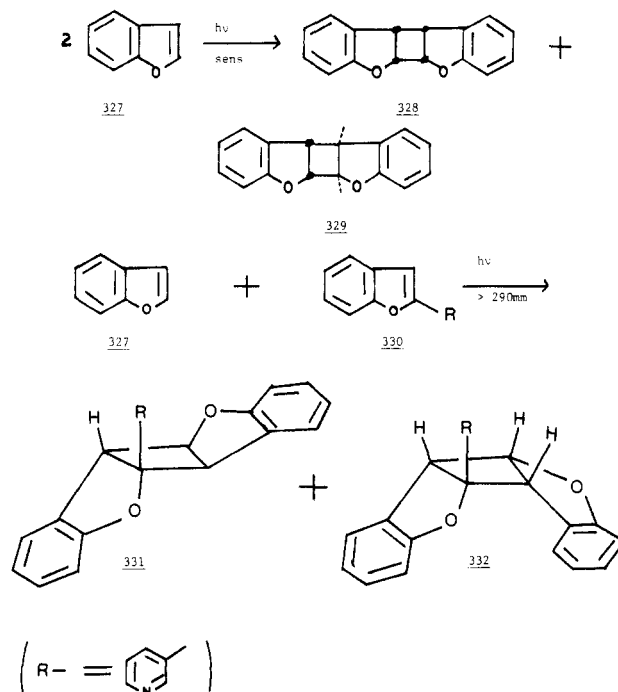

An interesting reaction was observed with benzofuran (**327**) and 2-(3-pyridyl)benzofuran (**330**).³²⁸ Irradiation through a Pyrex filter gave a mixture of the crossed photodimers **331** and **332** in 3.2 ratio. In this experiment only benzofuran (**327**) absorbed the incident light. However, no cycloadducts were observed on irradiation at 313 nm, where only the pyridylbenzofuran **330** absorbed the light.

Formation of **331** and **332** was neither sensitized with acetophenone nor quenched with naphthalene, and the excited singlet state of benzofuran (**327**) must be involved.³²⁸

Furan, thiophene, selenophene, and their benzo derivatives also undergo a number of mixed photoadditions.

Furan forms cyclobutane adducts with methyl maleic anhydride,³²⁹ oxetanes with aldehydes and ketones,^{329,330} and 1:1 adducts with benzene.¹²³ Thiophene and selenophene react with maleic anhydride derivatives, forming 1:1 cyclobutane adducts **333** and **334**.^{331,332} A

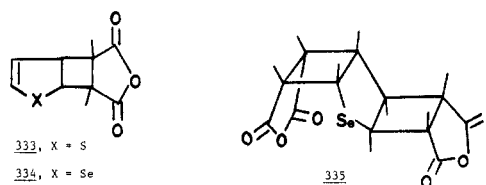

2:1 adduct (**335**) was also reported in the reaction of selenophene with 2,3-dimethylmaleic anhydride.³³²

Similarly, the selenophthene isomers **336** and **337** reacted with 2,3-dimethylmaleic anhydride (DMA) on sensitized (benzophenone) irradiation in benzene.³³² Both selenophthene isomers formed 1:1 adducts **338** and **339**, while **337** also formed a 2:1 adduct. The latter was not characterized completely owing to solubility problems.³³²

A number of mixed additions of benzofuran,^{305,334} benzothiophene,^{305,333,334} and benzoselenophene³³² with ethylene and acetylene derivatives are known. For

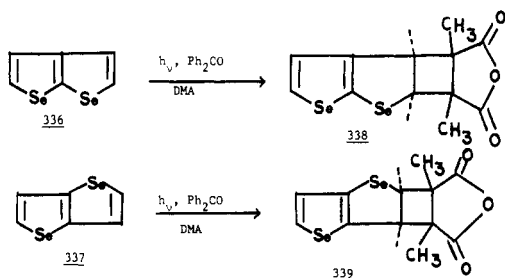

example, benzofuran and benzothiophene form **340** and **341**, respectively on triplet-sensitized addition of dimethylacetylene dicarboxylate.^{305,333,334}

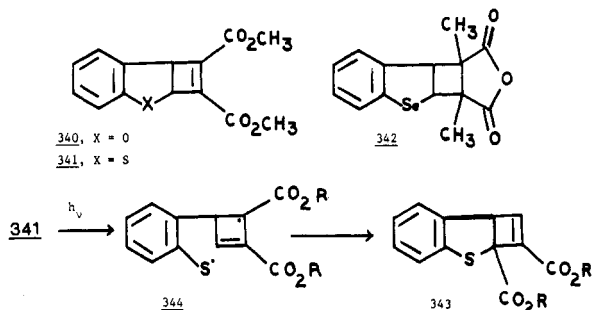

Benzoselenophene forms **342** on addition of dimethylmaleic anhydride.³³² These additions are assisted by electron-withdrawing groups in the alkene (alkyne) component.

The acetylenic adducts **340** and **341** rearrange in secondary photochemical reactions.^{305,333} For example, the benzothiophene adduct **341** rearranges to give the isomer **343** on irradiation.

The biradical intermediate **344** was proposed, which can ring close in two ways, giving either **341** or **343**. The benzofuran adduct **340** rearranges more extensively, and additional products are formed from both **340** and **341**.^{305,333}

Photocycloaddition of benzothiophene 1,1-dioxides to cycloalkenes is a reaction that promises to be useful in synthesis. Photoaddition of 3-acetoxybenzo[*b*]-thiophene 1,1-dioxide (**345**) in benzene-cyclohexene

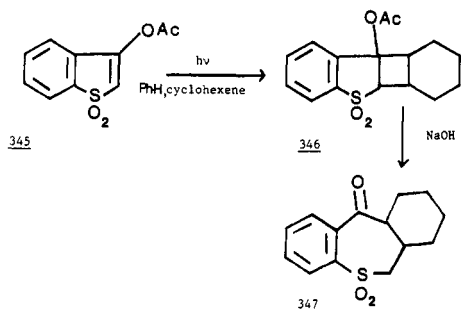

gave the cyclobutane **346** in 59% yield and a cyclobutane dimer of **345** (33%).³³⁵ A similar reaction occurred with cyclopentene. Treatment of cycloadduct **346** with sodium hydroxide in aqueous methanol gave a 72% yield of the benzo[*b*]thiepinone (**347**).³³⁵

D. Oxazole and Thiazole Derivatives

There is an increasing amount of photochemistry in the recent literature of five-membered ring heterocycles containing two heteroatoms.

The dimerization of 2-arylbenzoxazolines (**348**) on

irradiation in benzene was recently described.³³⁶ Dimer **349** was the only product when X = F. When X = Br

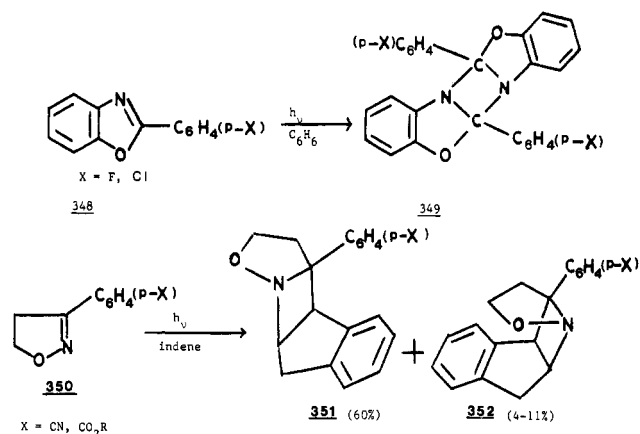

or I, dehalogenation occurred, while if X = Cl, dimerization and dehalogenation both took place. It was concluded that dimer formation occurred via the singlet, while dehalogenation was a triplet process.³³⁶

Photoaddition of indene and 3-aryl-2-isoxazolines (**350**) also affords 2 + 2 cycloadducts, with addition occurring at the C=N double bond, via an exciplex intermediate.³³⁷ The exo and endo adducts **351** and **352** are both formed, the former being the major product.³³⁷

Photoaddition of alkenes to 3-phenyl-1,2-benzisothiazole (**353**) follows a different pathway, and addition to the C=N double bond is not observed.³³⁴ Addition

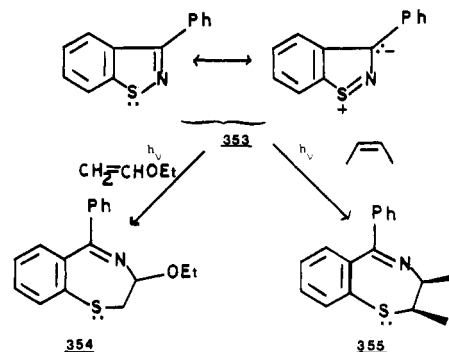

of **353** with ethyl vinyl ether gives **354**, and addition of *cis*-but-2-ene gives **355**. Note that in the latter adduct, the alkene stereochemistry is retained. Structure **354** was confirmed by X-ray crystal structure analysis.³³⁴ Several mechanisms were considered to account for the formation of ring-expanded products **354** and **355**. Possibilities include nitrogen-sulfur bond cleavage to form a biradical, which then adds to the alkene; addition via an ion pair; and concerted 2π + 2π addition to the nitrogen-sulfur bond, followed by ring expansion.

In view of the reaction stereochemistry, the third possibility is most reasonable, and addition to the ni-

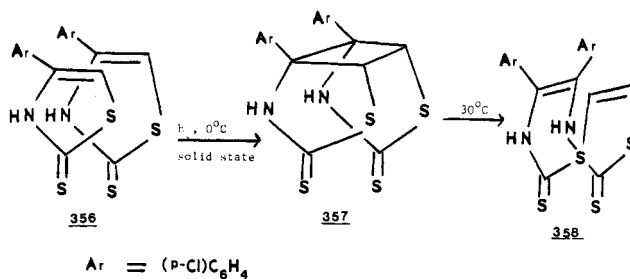

trogen-sulfur bond could be facilitated by the charge-separated resonance contributor to structure 353.

The solid-state photodimerization of 4-(*p*-chlorophenyl)thiazole-2(1*H*)-thione (356) has been reported.³³⁸ Irradiation of 356 in the solid state at 0 °C resulted in formation of cyclobutane dimer 357, which could be isolated if care was taken to prevent warming. At 30 °C, 357 collapsed to the macrocyclic compound 358. Apparently the chloro substituent in 356 was necessary to achieve a suitable crystal structure for dimerization.³³⁸

VIII. Addenda

This section has been included to mention relevant work, which, for one reason or another, was omitted from the main part of the review. The most significant omission is the recent work on triplet excimers^{339,340} and exciplexes.³⁴¹ These complexes are likely to be involved in photoaddition reactions, but the extent to which they are has not yet been determined.

Interest continues in 1,3-di(1-pyrenyl)propane (142) and related compounds. Viscosity effects on the excimer formation in 142 have been studied at high pressure.³⁴² The sensitivity of these excimers to their environment had led to their earlier use as probes of biological systems.^{343,344} Recently, 1,3-di- β -naphthylpropane has also been used as a biological probe.³⁴⁵ Intramolecular 2 + 2 cycloaddition of linked naphthalene and 3-phenylcyclopent-2-enone groups has been described,³⁴⁶ possibly the first case of an enone addition to a naphthalene ring. Finally, the factors affecting escape yields of radical ions from the initially formed caged ion pairs have been studied.³⁴⁷

Acknowledgments. The contributions of students, co-workers, and other colleagues is acknowledged. Unpublished data and helpful suggestions from various colleagues have been invaluable in our work and in the writing of this review.

IX. References and Notes

- McCullough, J. J.; Kelly, J. M.; Rasmussen, P. W. *J. Org. Chem.* **1969**, *34*, 2933.
- McCullough, J. J. *Acc. Chem. Res.* **1980**, *13*, 270 and references therein.
- Bowman, R. M.; Chamberlain, T. R.; Huang, C. W.; McCullough, J. J. *J. Am. Chem. Soc.* **1974**, *96*, 692.
- McCullough, J. J.; MacInnis, W. K.; Lock, C. J. L.; Faggiani, R. *J. Am. Chem. Soc.* **1980**, *102*, 7780.
- McCullough, J. J.; Wu, W. S. *J. Chem. Soc., Chem. Commun.* **1972**, 1136.
- McCullough, J. J.; Miller, R. C.; Wu, W. S. *Can. J. Chem.* **1977**, *55*, 2909.
- Corey, E. J.; Bass, J. D.; LeMahieu, R.; Mitra, R. B. *J. Am. Chem. Soc.* **1964**, *86*, 5570.
- Bowman, R. M.; Calvo, C.; McCullough, J. J.; Rasmussen, P. W. W.; Snyder, F. F. *J. Org. Chem.* **1972**, *37*, 2084.
- Wilkinson, F.; Dubois, J. J. *J. Chem. Phys.* **1963**, *39*, 377.
- Taylor, G. N. *Chem. Phys. Lett.* **1971**, *10*, 355.
- Ware, W. R.; Watt, D.; Holmes, J. D. *J. Am. Chem. Soc.* **1974**, *96*, 7853.
- Michl, J. *Photochem. Photobiol.* **1977**, *25*, 141. Gerhartz, W.; Poshusta, R. D.; Michl, J. *J. Am. Chem. Soc.* **1976**, *98*, 6427.
- Birks, J. B. *Photophysics of Aromatic Molecules*; Wiley-Interscience, London, 1970; Chapter 7.
- McCullough, J. J.; MacInnis, W. K.; Lock, C. J. L.; Faggiani, R. *J. Am. Chem. Soc.* **1982**, *104*, 4644.
- Forster, T.; Kasper, K. Z. *Phys. Chem. (Munich)* **1954**, *1*, 275.
- Birks, J. B.; Dyson, D. J.; Munro, I. H. *Proc. R. Soc. London, A* **1963**, *275*, 575.
- Birks, J. B. *Acta Phys. Pol.* **1968**, *34*, 599.
- Mataga, N.; Ottolenghi, M. In *Molecular Association*; Foster, R., Ed.; Academic: New York, 1979; Vol. 2, p 1 and references therein.
- Leonhardt, H.; Weller, A. *Ber. Bunsen-Ges. Phys. Chem.* **1963**, *67*, 791.
- Knibbe, H.; Rehm, D.; Weller, A. *Ber. Bunsen-Ges. Phys. Chem.* **1969**, *73*, 839.
- Rehm, D.; Weller, A. *Z. Phys. Chem. (Munich)* **1970**, *69*, 183.
- Weller, A. In *The Exciplex*; Gordon, M., Ware, W. R., Eds.; Academic: New York, 1975; p 23.
- Weller, A. *Pure Appl. Chem.* **1968**, *16*, 115.
- Ander, S.; Blume, H.; Heinrich, G.; Schulte-Frohlinde, D. *J. Chem. Soc., Chem. Commun.* **1968**, 745.
- Schulte-Frohlinde, D.; Pfefferkorn, R. *Ber. Bunsen-Ges. Phys. Chem.* **1968**, *72*, 330.
- Labianca, D. A.; Taylor, G. N.; Hammond, G. S. *J. Am. Chem. Soc.* **1972**, *94*, 3679 and references therein.
- Taylor, G. N.; Hammond, G. S. *J. Am. Chem. Soc.* **1972**, *94*, 3687.
- Evans, T. R. *J. Am. Chem. Soc.* **1971**, *93*, 2081.
- Guttenplan, J. B.; Cohen, S. G. *J. Am. Chem. Soc.* **1972**, *94*, 4040.
- Guttenplan, J. B.; Cohen, S. G. *Tetrahedron Lett.* **1972**, 2163.
- Rehm, D.; Weller, A. *Ber. Bunsen-Ges. Phys. Chem.* **1969**, *73*, 834.
- McCullough, J. J.; Yeroushalmi, S. *J. Chem. Soc., Chem. Commun.* **1983**, 254.
- Pysh, E. S.; Yang, N. C. *J. Am. Chem. Soc.* **1963**, *85*, 2124.
- Miller, L. L.; Nordblom, G. D.; Mayeda, E. A. *J. Org. Chem.* **1972**, *37*, 916.
- Taylor, G. N. *Chem. Phys. Lett.* **1971**, *10*, 355.
- O'Connor, D. V.; Ware, W. R. *J. Am. Chem. Soc.* **1976**, *98*, 4706; **1979**, *101*, 121.
- Caldwell, R. A.; Creed, D. *Acc. Chem. Res.* **1980**, *13*, 45.
- Lewis, N. A. *Acc. Chem. Res.* **1979**, *12*, 152.
- Meeus, F.; Van der Auweraer, M.; De Schryver, F. S. *J. Am. Chem. Soc.* **1980**, *102*, 4017.
- Van der Auweraer, M.; Gilbert, A.; De Schryver, F. C. *J. Am. Chem. Soc.* **1980**, *102*, 4007.
- Zachariasse, K. A.; Kuhnle, W. Presented at the 7th IUPAC Meeting on Photochemistry, Leuven, Belgium, 1978; Abstracts p 380.
- Murrell, J. N.; Tanaka, J. *Mol. Phys.* **1964**, *4*, 363.
- Eaton, D. F.; Pensak, D. A. *J. Phys. Chem.* **1981**, *85*, 2760.
- Van der Auweraer, M.; Swinnen, A. U.; De Schryver, F. C. *J. Chem. Phys.* **1982**, *77*, 4110 and references therein.
- Mataga, N. *The Exciplex*; Gordon, M., Ware, W. R., Eds.; Academic: New York, 1975; p 113.
- (a) Hayashi, T.; Mataga, N.; Sakata, Y.; Misumi, S. *Chem. Phys. Lett.* **1976**, *41*, 325. (b) Hayashi, T.; Suzuki, T.; Mataga, N.; Sakata, Y.; Misumi, S. *Ibid.* **1976**, *38*, 599.
- Equation 37 is similar to the relationship between solvent properties and the differences in absorption and emission frequencies (see Birks, J. B., ref 13, pp 113-119). Although eq 37 is widely used, it is an approximation. For complete discussions and derivations see: Birks, J. B., ref 13, pp 425-430, and ref 48-49.
- Beens, H.; Knibbe, H.; Weller, A. *J. Chem. Phys.* **1967**, *47*, 1183.
- Knibbe, H. "Charge-Transfer Complex Formation in the Excited State", Doctoral Thesis, the Free University of Amsterdam, 1969; pp 33-41.
- Kuzmin, M. G.; Guseva, L. N. *Chem. Phys. Lett.* **1969**, *8*, 71.
- Basu, S. *J. Photochem.* **1978**, *9*, 539.
- Chandross, E. A. In *The Exciplex*; Gordon, M., Ware, W. R., Eds.; Academic: New York, 1975; p 187.
- Knibbe, H.; Rollig, K.; Schafer, F. P.; Weller, A. *J. Chem. Phys.* **1967**, *47*, 1184.
- Grellmann, K. H.; Watkins, A. R.; Weller, A. *J. Lumin.* **1970**, *1/2*, 678.
- Grellmann, K. H.; Watkins, A. R.; Weller, S. *J. Phys. Chem.* **1972**, *76*, 469.
- Masuhara, H.; Mataga, N. *Acc. Chem. Res.* **1981**, *14*, 312.
- Ottolenghi, M. *Acc. Chem. Res.* **1973**, *6*, 153.
- Rehm, D.; Weller, A. *Isr. J. Chem.* **1970**, *8*, 259.
- (a) Masuhara, H.; Hino, T.; Mataga, N. *J. Phys. Chem.* **1975**, *79*, 994. (b) Grabner, G.; Rauscher, W.; Zecher, J.; Getoff, N. *J. Chem. Soc., Chem. Commun.* **1980**, 222. (c) Delcourt, M. O.; Rossi, M. J. *J. Phys. Chem.* **1982**, *86*, 3233.
- Suppan, P. *J. Chem. Soc., Faraday Trans. 1* **1986**, 509.
- (a) Loutfy, R. O.; Loutfy, R. O. *Can. J. Chem.* **1976**, *54*, 1454. (b) Treinin, A.; Hayon, E. *J. Am. Chem. Soc.* **1976**, *98*, 3884. (c) Kavarnos, G. J.; Turro, N. J. *J. Chem. Rev.* **1986**, *86*, 401.
- Bock, C. R.; Connor, J. A.; Gutierrez, A. R.; Meyer, T. J.; Whitten, D. G.; Sullivan, B. P.; Nagle, J. K. *J. Am. Chem. Soc.* **1979**, *101*, 4815. (b) Balzani, V.; Sabbatini, N.; Scandola, F. *Chem. Rev.* **1986**, *86*, 319 and references therein. (c) Sutin, N.; Creutz, C. *Pure Appl. Chem.* **1980**, *52*, 2717.
- (a) Seely, G. R. *Photochem. Photobiol.* **1978**, *27*, 639. (b) Natarajan, L. V.; Blankenship, R. E. *Ibid.* **1983**, *37*, 329.

- (64) (a) Marcus, R. A. *Annu. Rev. Chem.* 1964, 15, 155. (b) *J. Chem. Phys.* 1965, 43, 679.
- (65) Lewis, N. A. *J. Chem. Educ.* 1980, 57, 478.
- (66) Rau, H. Presented at the XI IUPAC Symposium on Photochemistry, Lisbon, Portugal, July 1986; papers 1-3.
- (67) Balzani, V.; Bolletta, F. *J. Am. Chem. Soc.* 1978, 100, 7404.
- (68) Seely, G. R. *Curr. Top. Bioenerg.* 1978, 7, 3.
- (69) Nagle, J. K.; Dressick, W. J.; Meyer, T. J. *J. Am. Chem. Soc.* 1979, 101, 3993.
- (70) Miller, J. R.; Calcaterra, L. T.; Closs, G. L. *J. Am. Chem. Soc.* 1984, 106, 3047.
- (71) Pasman, P.; Mes, G. F.; Koper, N. W.; Verhoeven, J. W. *J. Am. Chem. Soc.* 1985, 107, 5839.
- (72) Calvin, M. *Photochem. Photobiol.* 1983, 37, 349.
- (73) Gratzel, M. *Acc. Chem. Res.* 1981, 14, 376.
- (74) Gerischer, H. *Pure Appl. Chem.* 1980, 52, 2649.
- (75) Balzani, V.; Bolletta, F.; Scandola, F.; Ballardini, R. *Pure Appl. Chem.* 1979, 51, 299.
- (76) Taylor, G. N. *Solid State Tech.* 1980, 73.
- (77) Schuster, G. B. *Acc. Chem. Res.* 1979, 12, 366.
- (78) Fritsche, J. *J. Prakt. Chem.* 1867, 101, 333.
- (79) Bowen, E. J. *Adv. Photochem.* 1963, 1, 23.
- (80) Cowan, D. O.; Drisko, R. L. *Elements of Organic Photochemistry*; Plenum: New York, 1976. Chapter 2 gives a good summary of earlier work on anthracene.
- (81) Bouas-Laurent, H.; Castellán, A.; Desvergne, J.-P. *Pure Appl. Chem.* 1980, 52, 2633.
- (82) Castellán, A.; Lapouyade, R.; Bouas-Laurent, H. *Bull. Soc. Chim. Fr.* 1976, 210.
- (83) Vember, T. M.; Veselova, T. V.; Obyknovennaya, I. E.; Cherkasov, A. S.; Shirokov, V. I. *Izv. Akad. Nauk, SSSR, Ser. Fiz.* 1973, 37, 837.
- (84) Ehrenberg, M. *Acta Crystallogr., Sect. B: Struct. Crystallogr. Cryst. Chem.* 1968, B24, 1123.
- (85) (a) Teitei, T.; Wells, D.; Spurling, T. H.; Sasse, W. H. *F. Aust. J. Chem.* 1978, 31, 85. (b) Teitei, T.; Wells, D.; Sasse, W. H. *F. Aust. J. Chem.* 1976, 29, 1783. (c) Kowala, C.; Sugowdz, G.; Sasse, W. H. F.; Wunderlich, J. A. *Tetrahedron Lett.* 1972, 4721.
- (86) Seliger, B. K.; Sterns, M. *J. Chem. Soc., Chem. Commun.* 1969, 978.
- (87) Ehrenberg, M. *Acta Crystallogr.* 1966, 20, 177.
- (88) (a) Mattingly, T. W.; Lancaster, J. E.; Zweig, A. *J. Chem. Soc., Chem. Commun.* 1971, 595. (b) Albini, A.; Giannantonio, L. *J. Org. Chem.* 1984, 49, 3863.
- (89) Tobe, Y.; Hirata, F.; Nishida, K.; Fujita, H.; Kimura, K.; Odaira, Y. *J. Chem. Soc., Chem. Commun.* 1981, 786.
- (90) (a) Hartmann, I.-M.; Hartmann, W.; Schenck, G. O. *Chem. Ber.* 1967, 100, 3146. (b) Mayer, H.; Schuster, F.; Sauer, J. *Tetrahedron Lett.* 1986, 1289.
- (91) Cowan, D. O.; Kozziak, J. C. *J. Am. Chem. Soc.* 1975, 97, 249.
- (92) Nerbonne, J. M.; Weiss, R. G. *J. Am. Chem. Soc.* 1979, 101, 402.
- (93) Castellán, A.; Dumartin, G.; Galante, R.; Bouas-Laurent, H. *Bull. Soc. Chim. Fr.* 1976, 217.
- (94) Hoffman, R.; Wells, P.; Morrison, H. *J. Org. Chem.* 1971, 36, 102.
- (95) McCullough, J. J. *Can. J. Chem.* 1968, 46, 43 and references therein.
- (96) Kozziak, J. C.; Cowan, D. O. *Acc. Chem. Res.* 1978, 11, 334.
- (97) (a) Birks, J. B. *Photochem. Photobiol.* 1976, 24, 287. (b) Morrison, H.; Miller, A. *Tetrahedron* 1981, 37, 3405. Kinetics of the heavy atom effect are discussed in these references.
- (98) Wittig, G.; Koenig, G.; Claus, K. *Liebigs Ann. Chem.* 1955, 593, 127.
- (99) Sargent, M. V.; Timmons, C. J. *J. Chem. Soc.* 1964, 5544.
- (100) Caldwell, R. A.; Ghali, N. I.; Chien, C.-K.; DeMarco, D.; Smith, L. *J. Am. Chem. Soc.* 1978, 100, 2857.
- (101) Schenck, A. O.; Hartmann, W.; Mannsfeld, S.-P.; Metzner, W.; Krauch, C. H. *Chem. Ber.* 1962, 95, 1642.
- (102) Bowyer, J.; Porter, Q. N. *Aust. J. Chem.* 1966, 19, 1455.
- (103) Burks, J. E.; Vander Helm, D.; Dobbs, T. K.; Ansell, L. L.; Ruehle, P. H.; Eisenbraun, E. J. *Acta Cryst.* 1978, B34, 496.
- (104) Hoffmann, R.; Wells, P.; Morrison, H. *J. Org. Chem.* 1972, 36, 102 and references therein.
- (105) Brown, W. G.; Markezich, R. L. *Abstracts of Papers, 153rd National Meeting of the American Chemical Society, Miami Beach, FL; American Chemical Society: Washington, DC, 1967; Abstract 0-139.*
- (106) Dodson, R. M.; Zielske, A. G. *J. Org. Chem.* 1967, 32, 28.
- (107) Shirota, Y.; Nishikata, A.; Aoyama, T.; Saimatsu, J.; Shin-Col, O.; Mikawa, H. *J. Chem. Soc., Chem. Commun.* 1984, 64.
- (108) Dauben, W. G.; van Riel, H. C.; Hauw, C.; Leroy, F.; Jousot-Dubien, J.; Bonneau, R. *J. Am. Chem. Soc.* 1979, 101, 1901.
- (109) Dauben, W. G.; van Riel, H. C.; Robbins, J. D.; Wagner, G. *J. Am. Chem. Soc.* 1979, 101, 6383.
- (110) Rosenberg, H. M.; Serve, M. P. *J. Org. Chem.* 1972, 37, 141.
- (111) Jousot-Dubien, J.; Bonneau, R.; Fournier de Violet, P. In *Excited States in Organic Chemistry and Biochemistry*; Pullman, B., Goldblum, N., Eds.; D. Reidel: Dordrecht, Holland, 1977; p 271.
- (112) McCullough, J. J.; Ohorodnyk, H.; Santry, D. P. *J. Chem. Soc., Chem. Commun.* 1969, 570.
- (113) Syamala, M. S.; Ramamurthy, V. *J. Org. Chem.* 1986, 51, 3712 and references therein.
- (114) Ulrich, H.; Rao, D. V.; Stuber, F. A.; Sayigh, A. A. R. *J. Org. Chem.* 1970, 35, 1121.
- (115) (a) Cohen, M. D. *Pure Appl. Chem.* 1965, 9, 567. *Angew. Chem., Int. Ed. Engl.* 1975, 14, 386. (b) Nishikubo, T.; Takahashi, E.; Uiyaji, T.; Izawa, T. *Bull. Chem. Soc. Jpn.* 1985, 58, 3399.
- (116) Schonberg, A. *Preparative Organic Photochemistry*; Springer-Verlag: New York, 1968; pp 83-85. Experimental details for the preparation of α -truxillic and β -truxinic acids. See, however, ref 115b.
- (117) Lewis, F. D.; Oxman, J. D.; Huffman, J. C. *J. Am. Chem. Soc.* 1984, 106, 466.
- (118) Egerton, P. L.; Hyde, E. M.; Trigg, J.; Payne, A.; Beynon, P.; Mijonic, M. V.; Reiser, A. *J. Am. Chem. Soc.* 1981, 103, 3859.
- (119) Damen, J.; Neckers, D. C. *J. Am. Chem. Soc.* 1980, 102, 3265.
- (120) Koch, H.; Laschewsky, A.; Ringsdorf, H.; Teng, K. *Makromol. Chem.* 1986, 187, 1843.
- (121) Lewis, F. D.; Howard, D. K.; Oxman, J. D. *J. Am. Chem. Soc.* 1983, 105, 3344.
- (122) Cundall, R. B.; Robinson, D. A.; Periera, L. C. *Adv. Photochem.* 1977, 10, 147.
- (123) Bryce-Smith, D.; Gilbert, A. *Tetrahedron* 1976, 32, 1309; 1977, 33, 2459.
- (124) Gilbert, A.; Yianni, P. *Tetrahedron* 1981, 37, 3275.
- (125) Job, B. E.; Littlehales, H. D. *J. Chem. Soc. C* 1968, 886.
- (126) (a) Ohashi, M.; Tanaka, Y.; Yamada, S. *J. Chem. Soc., Chem. Commun.* 1976, 800. (b) *Idem. Tetrahedron Lett.* 1977, 3629.
- (127) Ohashi, M.; Yoshino, A.; Yamasaki, K.; Yonezawa, T. *Tetrahedron Lett.* 1973, 3395.
- (128) Bryce-Smith, D.; Gilbert, G.; Orger, B.; Tyrell, H. *J. Chem. Soc., Chem. Commun.* 1974, 334.
- (129) Cornelisse, J.; Merritt, V. Y.; Srinivasan, R. *J. Am. Chem. Soc.* 1973, 95, 6197.
- (130) Srinivasan, R. *J. Phys. Chem.* 1972, 76, 15.
- (131) (a) Srinivasan, R. *IBM J. Res. Dev.* 1971, 15, 34. (b) Cornelisse, J.; Srinivasan, R. *Chem. Phys. Lett.* 1973, 20, 278.
- (132) (a) Bryce-Smith, D.; Drew, M. G. B.; Fenton, G. A.; Gilbert, A. *J. Chem. Soc., Chem. Commun.* 1985, 607. (b) Bryce-Smith, D.; Gilbert, A.; Mattay, J. *Tetrahedron Lett.* 1986, 6011.
- (133) Buchi, G.; Atkinson, J. G.; Ayer, D. E.; Robb, E. W. *J. Am. Chem. Soc.* 1963, 85, 2257.
- (134) Cantrell, T. S. *J. Am. Chem. Soc.* 1972, 94, 5929. *J. Org. Chem.* 1977, 42, 4238.
- (135) Yang, N. C.; Kim, B.; Chiang, W.; Hamada, T. *J. Chem. Soc., Chem. Commun.* 1976, 729.
- (136) (a) Lewis, F. D.; Holman, B. *J. Phys. Chem.* 1980, 84, 2326. (b) *Ibid.* 1980, 84, 2328.
- (137) Bryce-Smith, D.; Foulger, B. E.; Gilbert, A. *J. Chem. Soc., Chem. Commun.* 1972, 664.
- (138) (a) Sket, B.; Zupan, M. *J. Am. Chem. Soc.* 1977, 99, 3504. (b) *Idem. Tetrahedron Lett.* 1977, 2811 and references therein.
- (139) Lewis, F. D.; Hoyle, C. E.; Johnson, D. E. *J. Am. Chem. Soc.* 1975, 97, 3267.
- (140) Caldwell, R. A.; Ghali, N. I.; Chien, C.-K.; De Marco, D.; Smith, L. *J. Am. Chem. Soc.* 1978, 100, 2857.
- (141) Ward, H. R.; Wishnook, J. S. *J. Am. Chem. Soc.* 1968, 90, 1085.
- (142) Kaplan, L.; Wilzbach, K. E. *J. Am. Chem. Soc.* 1967, 89, 1030; 1968, 90, 3291. Wilzbach, K. E.; Ritscher, J. S.; Kaplan, L. *Ibid.* 1967, 89, 1031.
- (143) Zimmerman, H. E. *Acc. Chem. Res.* 1971, 4, 272.
- (144) Zimmerman, H. E. *Quantum Mechanics for Organic Chemists*; Academic: New York, 1975; pp 35-43.
- (145) (a) Sheridan, R. S. *J. Am. Chem. Soc.* 1983, 105, 5140. (b) Reedich, D. E.; Sheridan, R. S. *Ibid.* 1985, 107, 3360. (c) Osselton, E. M.; Eyken, C. P.; Jans, A. W. H.; Cornelisse, J. *Tetrahedron Lett.* 1985, 1577.
- (146) (a) Leismann, H.; Mattay, J.; Scharf, H.-D. *J. Am. Chem. Soc.* 1984, 106, 3985. (b) Mattay, J.; Runsink, J.; Leismann, H.; Scharf, H.-D. *Tetrahedron Lett.* 1982, 4919.
- (147) Carr, R. V.; Kim, B.; McVey, J. K.; Yang, N. C.; Gerhartz, W.; Michl, J. *Chem. Phys. Lett.* 1976, 39, 57 and references therein.
- (148) Katz, T. J.; Wang, E. J.; Acton, N. *J. Am. Chem. Soc.* 1971, 93, 3782.
- (149) Mandella, W. L.; Franck, R. W. *J. Am. Chem. Soc.* 1973, 95, 971.
- (150) Bowman, R. M.; Calvo, C.; McCullough, J. J.; Miller, R. C.; Singh, I. *Can. J. Chem.* 1973, 51, 1060.
- (151) McCullough, J. J.; Akhtar, I. A.; Montgomery, C., unpublished results.
- (152) Akhtar, I. A.; McCullough, J. J. *J. Org. Chem.* 1981, 46, 1447.
- (153) See also: Bowman, R. M.; Huang, C. W.; McCullough, J. J. *Org. Photochem. Synth.* 1976, 21, 28. Chamberlain, T. R.; Miller, R. C.; McCullough, J. J. *Ibid.* 1976, 2, 30. Suginome,

- H.; Liu, C. F.; Tokuda, M. *J. Chem. Soc., Chem. Commun.* **1984**, 334.
- (154) Sakurai, H.; Pac, C. *Mem. Inst. Sci. Ind. Res., Osaka Univ.* **1980**, *37*, 59.
- (155) Pac, C.; Sugioka, T.; Mizuno, K.; Sakurai, H. *Bull. Chem. Soc. Jpn.* **1973**, *46*, 238.
- (156) Mizuno, K.; Pac, C.; Sakurai, H. *J. Chem. Soc., Chem. Commun.* **1974**, 648.
- (157) Chamberlain, T. R.; McCullough, J. J. *Can. J. Chem.* **1973**, *51*, 2578.
- (158) Mizuno, K.; Pac, C.; Sakurai, H. *J. Chem. Soc., Perkin Trans. 1* **1975**, 2221.
- (159) Bryce-Smith, D.; Foulger, B. E.; Forrester, J.; Gilbert, A.; Orger, B. H.; Tyrrell, H. M. *J. Chem. Soc., Perkin Trans. 1* **1980**, 55.
- (160) Pac, C.; Sugioka, T.; Sakurai, H. *Chem. Lett.* **1972**, 39.
- (161) Kan, K.; Kai, Y.; Yasuoka, N.; Kasai, N. *Bull. Chem. Soc. Jpn.* **1979**, *52*, 1634.
- (162) (a) Sugioka, T.; Pac, C.; Sakurai, H. *Chem. Lett.* **1972**, 6567; **1972**, 791.
- (163) Mizuno, K.; Pac, C.; Sakurai, H. *J. Chem. Soc., Perkin Trans. 1* **1974**, 2360.
- (164) Sasse, W. H. F. *Aust. J. Chem.* **1969**, *22*, 1257.
- (165) Kowala, C.; Poppleton, B. J.; Sasse, W. H. F. *Aust. J. Chem.* **1976**, *29*, 1851.
- (166) Sasse, W. H. F.; Collin, P. J.; Sugowdz, G. *Tetrahedron Lett.* **1965**, 3373.
- (167) Teitei, T.; Wells, D.; Sasse, W. H. F. *Aust. J. Chem.* **1975**, *28*, 571.
- (168) (a) Sasse, W. H. F.; Collin, P. J.; Roberts, D. B.; Sugowdz, G. *Aust. J. Chem.* **1971**, *24*, 2339. (b) Teitei, T.; Collin, P. J.; Sasse, W. H. F. *Ibid.* **1972**, *25*, 171.
- (169) Grovenstein, E.; Campbell, T. C.; Shibata, T. *J. Org. Chem.* **1969**, *34*, 2418.
- (170) Bender, C. O.; Cassis, I. M.; Dolman, D.; Heerze, L. D.; Schulz, F. L. *Can. J. Chem.* **1984**, *62*, 2769.
- (171) Scharf, H.-D.; Leismann, H.; Erb, W.; Gaidetzka, H. W.; Ar-etz, J. *Pure Appl. Chem.* **1974**, *41*, 581.
- (172) Viehe, H. G.; Janousek, Z.; Merenyi, R.; Stella, L. *Acc. Chem. Res.* **1985**, *18*, 141.
- (173) Dopp, D.; Kruger, C.; Memarian, H. R.; Tsay, Y.-H. *Angew. Chem., Int. Ed. Engl.* **1985**, *24*, 1048.
- (174) Kjell, D. P.; Sheridan, R. S. *J. Am. Chem. Soc.* **1986**, *108*, 4111.
- (175) Yang, N. C.; Yates, R. L.; Masnovi, J.; Shold, D. M.; Chiang, W. E. *Pure Appl. Chem.* **1979**, *51*, 173 and references therein.
- (176) Yang, N. C.; Libman, J.; Savitzky, M. F. *J. Am. Chem. Soc.* **1972**, *94*, 9226.
- (177) Mak, K. T.; Srinivasachar, K.; Yang, N. C. *J. Chem. Soc., Chem. Commun.* **1979**, 1038.
- (178) Yang, N. C.; Chen, M.-J.; Chen, P.; Mak, K. T. *J. Am. Chem. Soc.* **1982**, *104*, 853.
- (179) Yang, N. C.; Masnovi, J.; Chiang, W.-L.; Wang, T.; Shou, H.; Yang, D. D. H. *Tetrahedron* **1981**, *37*, 3285.
- (180) Sasaki, T.; Kanematsu, K.; Hayakawa, K. *J. Am. Chem. Soc.* **1973**, *95*, 5632.
- (181) Yang, N. C.; Srinivasachar, K. *J. Chem. Soc., Chem. Commun.* **1976**, 48.
- (182) Yang, N. C.; Libman, J. *Tetrahedron Lett.* **1973**, 1409.
- (183) Kaup, G.; Teufel, E. *Chem. Ber.* **1980**, *113*, 3669.
- (184) Saltiel, J.; Dabestani, R.; Schwanze, K. S.; Trojan, D.; Townsend, D. E.; Goedken, V. L. *J. Am. Chem. Soc.* **1986**, *108*, 2674.
- (185) Smothers, W. K.; Meyer, U. C.; Saltiel, J. *J. Am. Chem. Soc.* **1983**, *105*, 545.
- (186) Shields, J. E.; Gavrilovic, D.; Kpecky, J.; Hartmann, W.; Heine, H.-G. *J. Org. Chem.* **1974**, *39*, 515.
- (187) Plummer, B. F.; Hall, R. A. *J. Chem. Soc., Chem. Commun.* **1970**, 44.
- (188) Petty, R. L.; Samuelson, G. E.; Boriack, C. J.; Onan, K. D.; McPhail, A. T.; Meinwald, J. *J. Am. Chem. Soc.* **1978**, *100*, 2464.
- (189) Shirota, Y.; Nagata, J.-I.; Mikawa, H. *Chem. Lett.* **1972**, 49.
- (190) (a) McCullough, J. J.; Huang, C. W. *J. Chem. Soc., Chem. Commun.* **1967**, 815. (b) *Can. J. Chem.* **1969**, *47*, 757.
- (191) Bowman, R. M.; McCullough, J. J.; Swenton, J. S. *Can. J. Chem.* **1969**, *47*, 4503.
- (192) Metzner, W.; Partale, H.; Krauch, C. H. *Chem. Ber.* **1967**, *100*, 3156.
- (193) Metzner, W.; Hartmann, W. *Chem. Ber.* **1968**, *101*, 4099.
- (194) Kimoto, H.; Takahashi, K.; Muramatsu, H. *Bull. Chem. Soc. Jpn.* **1980**, *53*, 764.
- (195) Swenton, J. S.; Krubsack, A. J. *J. Am. Chem. Soc.* **1969**, *91*, 786.
- (196) Mizuno, K.; Okamoto, H.; Pac, C.; Sakurai, H.; Murai, S.; Sonoda, N. *Chem. Lett.* **1975**, 237.
- (197) (a) Saltiel, J.; Charlton, J. L. In *Rearrangements in Ground and Excited States*; de Mayo, P., Ed.; Academic: New York, 1980; Vol. 3, p 25. (b) Schulte-Frohlinde, D.; Gainer, H. *Pure Appl. Chem.* **1979**, *51*, 279.
- (198) Steimitz, F. R. *Org. Photochem.* **1967**, *1*, 247.
- (199) This cyclization has been utilized in an attempted synthesis of the antileukemic substance juncusol: Kende, A. S.; Curran, D. P. *J. Am. Chem. Soc.* **1979**, *101*, 1857.
- (200) Lewis, F. D.; Hirsch, R. H. *J. Am. Chem. Soc.* **1976**, *98*, 5914.
- (201) Lewis, F. D.; Hirsch, R. H.; Roach, P. M.; Johnson, D. E. *J. Am. Chem. Soc.* **1976**, *98*, 8438.
- (202) Green, B. S.; Rejto, M.; Johnson, D. E.; Hoyle, C. E.; Simpson, J. T.; Correa, P. E.; Ho, T.-I.; McCoy, F.; Lewis, F. D. *J. Am. Chem. Soc.* **1979**, *101*, 3325.
- (203) Farid, S.; Doty, J. C.; Williams, J. L. R. *J. Chem. Soc., Chem. Commun.* **1972**, 711. See also ref 182.
- (204) Caldwell, R. A.; Smith, L. *J. Am. Chem. Soc.* **1974**, *96*, 2994.
- (205) Caldwell, R. A.; Creed, D.; De Marco, D. C.; Melton, L. A.; Ohta, H.; Wine, P. H. *J. Am. Chem. Soc.* **1980**, *102*, 2369.
- (206) Creed, D.; Caldwell, R. A.; Ulrich, M. M. *J. Am. Chem. Soc.* **1978**, *100*, 5831.
- (207) Caldwell, R. A.; Maw, T.-S. *J. Photochem.* **1979**, *11*, 165.
- (208) Bryce-Smith, D.; Vickery, B. *Chem. Ind. (London)* **1961**, 429.
- (209) Miyamoto, T.; Mori, T.; Odaira, Y. *J. Chem. Soc., Chem. Commun.* **1970**, 1598.
- (210) Fleming, I. *Frontier Orbitals and Organic Chemical Reactions*; Wiley: London, 1976; Chapter 6.
- (211) Lewis, F. D.; Hoyle, E. C. E.; Johnson, D. E. *J. Am. Chem. Soc.* **1975**, *97*, 3267.
- (212) Ohta, H.; Creed, D.; Wine, P. H.; Caldwell, R. A.; Melton, L. A. *J. Am. Chem. Soc.* **1975**, *98*, 2002.
- (213) Lewis, F. D.; Hoyle, E. C. E. *J. Am. Chem. Soc.* **1977**, *99*, 3779.
- (214) Chapman, O. L.; Lura, R. D. *J. Am. Chem. Soc.* **1970**, *92*, 6352.
- (215) Wells, P. P.; Morrison, H. *J. Am. Chem. Soc.* **1975**, *97*, 154.
- (216) Shim, S. C.; Kim, Y. Z. *J. Photochem.* **1983**, *23*, 83.
- (217) De Boer, C. D.; Schlessinger, R. H. *J. Am. Chem. Soc.* **1968**, *90*, 803.
- (218) De Boer, C. D. *J. Am. Chem. Soc.* **1969**, *91*, 1855.
- (219) Yang, N. C.; Shold, D. M.; Kim, B. *J. Am. Chem. Soc.* **1976**, *98*, 6587.
- (220) Saltiel, J.; Townsend, D. E.; Watson, B. D.; Shannon, P.; Finson, S. L. *J. Am. Chem. Soc.* **1977**, *99*, 884.
- (221) (a) Caldwell, R. A.; Creed, D. *J. Am. Chem. Soc.* **1979**, *101*, 6960. (b) *Ibid.* **1978**, *100*, 2905.
- (222) Formosinho, S. J. *Mol. Photochem.* **1976**, *7*, 41.
- (223) Yee, W. A.; Kuzmin, V. A.; Klinger, D. S.; Hammond, G. S.; Twarowski, A. J. *J. Am. Chem. Soc.* **1979**, *101*, 5104.
- (224) McCullough, J. J.; Miller, R. C., unpublished results.
- (225) (a) De Schryver, F. C.; Boens, N.; Put, J. *Adv. Photochem.* **1977**, *10*, 359. (b) De Schryver, F. C.; Boens, N.; Huybrechts, J.; Daemen, J.; De Brackelaire, M. *Pure Appl. Chem.* **1977**, *49*, 237. (c) Castellán, A.; Desvergne, J.-P.; Lesclaux, R.; Solognac, J.-C. *Chem. Phys. Lett.* **1984**, *106*, 117.
- (226) Davidson, R. S. *Adv. Phys. Org. Chem.* **1983**, *19*, 1.
- (227) Bouas-Laurent, H.; Castellán, A.; Desvergne, J.-P. *Pure Appl. Chem.* **1980**, *52*, 2633.
- (228) Goldenberg, M.; Emert, J.; Horawetz, H. *J. Am. Chem. Soc.* **1978**, *100*, 7171.
- (229) (a) Sakuragi, H.; Tokumaru, K.; Itoh, H.; Terakawa, K.; Kikuchi, K.; Caldwell, R. A.; Hsu, C. C. *J. Am. Chem. Soc.* **1982**, *104*, 6796. (b) Vanderauwera, P.; De Schryver, F. C.; Weller, A.; Winnik, M. A.; Zachariasse, K. A. *J. Phys. Chem.* **1984**, *88*, 2964. (c) Costa, S. M. B.; Prieto, M. J.; Davidson, R. S. *J. Photochem.* **1980**, *12*, 1. (d) Costa, S. M. B.; Prieto, M. J.; Ghiggino, K. P.; Phillips, D.; Roberts, A. J. *Ibid.* **1980**, *12*, 11.
- (230) (a) Hixson, S. S.; Mariano, P. S.; Zimmerman, H. E. *Chem. Rev.* **1973**, *73*, 531. (b) Zimmerman, H. E. In *Rearrangements in Ground and Excited States*; Academic: New York, 1980; Vol. 3, p 131.
- (231) (a) Zachariasse, K. A.; Duveneck, G.; Busse, R. *J. Am. Chem. Soc.* **1984**, *106*, 1045. (b) Zachariasse, K. A.; Busse, R.; Duveneck, G.; Kuhnle, W. *J. Photochem.* **1985**, *28*, 237.
- (232) Meeus, F.; Van Der Auweraer, M.; De Schryver, F. C. *Chem. Phys. Lett.* **1980**, *74*, 218.
- (233) McCullough, J. J.; MacInnis, W. K.; Eaton, D. F. *Chem. Phys. Lett.* **1986**, *125*, 155.
- (234) Iwamura, H. *J. Mol. Struct.* **1985**, *126*, 401 and references therein.
- (235) Van Der Auweraer, M.; Gilbert, A.; De Schryver, F. C. *Nouv. J. Chem.* **1980**, *4*, 153.
- (236) Swinnen, A. U.; Van der Auweraer, M.; De Schryver, F. C.; Nakatani, K.; Okada, T.; Matago, N. *J. Am. Chem. Soc.* **1987**, *109*, 321.
- (237) Hirayama, F. *J. Chem. Phys.* **1965**, *42*, 3163.
- (238) Chandross, E. A.; Dempster, C. J. *J. Am. Chem. Soc.* **1970**, *92*, 704.
- (239) Zachariasse, K.; Kuhnle, W. *Z. Phys. Chem. (Munich)* **1976**, *101*, 267.
- (240) Illuminati, G.; Mandolin, L. *Acc. Chem. Res.* **1981**, *14*, 95.
- (241) Chandross, E. A.; Dempster, C. J. *J. Am. Chem. Soc.* **1970**, *92*, 703.
- (242) Todesco, R.; Gelan, J.; Martens, H.; Put, J.; Boens, N.; De Schryver, F. C. *Tetrahedron Lett.* **1978**, 2815.

- (243) Desvergne, J.-P.; Bitit, N.; Castellán, A.; Bouas-Laurent, H. *J. Chem. Soc., Perkin Trans. 2* 1983, 109.
- (244) Chandross, E. A.; Schiebel, A. H. *J. Am. Chem. Soc.* 1973, 95, 611.
- (245) (a) Morrison, H. *Acc. Chem. Res.* 1979, 12, 383. (b) Pallmer, M.; Morrison, H. *J. Org. Chem.* 1980, 45, 798.
- (246) (a) Gilbert, A.; Taylor, G. N. *J. Chem. Soc., Chem. Commun.* 1979, 229. (b) Ellis-Davies, G. C. R.; Gilbert, A.; Heath, P.; Lane, J. C.; Warrington, J. V.; Westover, D. L. *J. Chem. Soc., Perkin Trans. 2* 1984, 1833.
- (247) Neijenesch, H.; De Ruiter, R.; Ridderikhoff, H.; Cornelisse, J. Presented at the XI IUPAC Symposium on Photochemistry, Lisbon, Portugal, July 27-Aug 1, 1986; Abstract 4P-5.
- (248) (a) Wender, P. A.; Howbert, J. *J. Am. Chem. Soc.* 1981, 103, 688. (b) Wender, P. A.; Dreyer, G. B. *Tetrahedron* 1981, 37, 4445. (c) Wender, P. A.; Howbert, J. *Tetrahedron Lett.* 1982, 23, 3983.
- (249) (a) Mani, J.; Cho, J.-H.; Astik, R. R.; Stamm, E.; Bigler, P.; Meyers, V.; Keese, R. *Helv. Chim. Acta* 1984, 67, 1930. (b) Mani, J.; Keese, R. *Tetrahedron* 1985, 41, 5697.
- (250) (a) Fischer, G.; Beckman, E.; Prinzbach, H.; Rihs, G.; Wirz, J. *Tetrahedron Lett.* 1986, 1273. (b) Sedelmeyer, G.; Fessner, W. D.; Grund, C.; Spurr, P. R.; Fritz, H.; Prinzbach, H. *Ibid.* 1986, 1277 and references therein.
- (251) Higuchi, H.; Kobayashi, E.; Sakata, Y.; Misumi, S. *Tetrahedron* 1986, 42, 1731.
- (252) Yang, N. C.; Horner, U. G. *Tetrahedron Lett.* 1986, 543.
- (253) Anderson, B. F.; Ferguson, J.; Morita, M.; Robertson, G. B. *J. Am. Chem. Soc.* 1979, 101, 1832.
- (254) Hayashi, T.; Suzuki, T.; Mataga, N.; Sakata, Y.; Misumi, S. *Chem. Phys. Lett.* 1976, 38, 599.
- (255) Hayashi, T.; Mataga, N.; Sakata, S.; Morita, M.; Tanaka, J. *J. Am. Chem. Soc.* 1976, 98, 5910.
- (256) Kaupp, G.; Zimmerman, I. *Angew. Chem., Int. Ed. Engl.* 1976, 15, 441.
- (257) Toyoda, T.; Kasai, N.; Misumi, S. *Bull. Chem. Soc. Jpn.* 1985, 58, 2348.
- (258) Kaupp, G. *Angew. Chem., Int. Ed. Engl.* 1976, 15, 442.
- (259) Becker, H. D.; Kjell, A. *Tetrahedron Lett.* 1985, 6129.
- (260) Becker, H. D.; Hansen, L.; Kjell, A. *J. Org. Chem.* 1986, 51, 2956.
- (261) Saltiel, J.; Marchand, G. R.; Dabestani, R.; Pecha, J. U. *Chem. Phys. Lett.* 1983, 100, 219.
- (262) (a) Becker, H. D.; Anderson, K.; Sandros, K. *J. Org. Chem.* 1985, 50, 3913. (b) Becker, H. D.; Soerensen, H.; Sandros, K. *Ibid.* 1986, 51, 3223.
- (263) Zertani, R.; Meier, H. *Chem. Ber.* 1986, 119, 1704 and references therein.
- (264) Padwa, A.; Goldstein, S.; Pulwer, U. *J. Org. Chem.* 1982, 47, 3893.
- (265) Ors, J. A.; Srinivasan, R. *J. Am. Chem. Soc.* 1978, 100, 315. *J. Chem. Soc., Chem. Commun.* 1978, 400.
- (266) Desvergne, J.-P.; Bitit, N.; Bouas-Laurent, H. *J. Chem. Res. Synop.* 1984, 214; *Miniprint* 1984, 1901.
- (267) Castellán, A.; Desvergne, J.-P.; Bouas-Laurent, H. *Chem. Phys. Lett.* 1980, 76, 390.
- (268) McCullough, J. J.; Wu, W. S. *J. Chem. Soc., Chem. Commun.* 1972, 1136.
- (269) Lewis, N. A.; De Voe, R. J. *Tetrahedron* 1982, 38, 1069.
- (270) Mizuno, K.; Pac, C.; Sakurai, H. *J. Am. Chem. Soc.* 1974, 96, 2993.
- (271) Lewis, N. A.; De Voe, R. J.; Mac Blane, D. B. *J. Org. Chem.* 1982, 47, 1392.
- (272) Arnaud, D. R.; Wong, P. C.; Maroulis, A. J.; Cameron, T. S. *Pure Appl. Chem.* 1980, 52, 2609.
- (273) (a) Albini, A.; Fasani, E.; Oberti, R. *Tetrahedron* 1982, 38, 1027. (b) Albini, A.; Fasani, E.; Sulpizio, A. *J. Am. Chem. Soc.* 1984, 106, 3562. (c) Albini, A.; Fasani, E.; Mella, U. *Ibid.* 1986, 108, 4119. (d) Lewis, N. A.; Petisce, J. R. *Tetrahedron* 1986, 42, 6207.
- (274) Yang, N. C.; Libman, J. *J. Am. Chem. Soc.* 1973, 95, 5783.
- (275) (a) Manring, L. E.; Peters, K. S. *J. Am. Chem. Soc.* 1985, 107, 6452. (b) Simon, J. D.; Peters, K. S. *Ibid.* 1981, 103, 6403.
- (276) Schlesener, C. J.; Amatore, C.; Kochi, J. K. *J. Am. Chem. Soc.* 1984, 106, 7472 and references therein.
- (277) (a) Yoshino, U.; Yamasaki, K.; Yonezawa, T.; Ohashi, U. *J. Chem. Soc., Perkin Trans. 1* 1975, 735. (b) Ohashi, U.; Nakayama, N. *Chem. Lett.* 1976, 1143.
- (278) Okashi, U.; Kudo, H.; Yamada, S. *J. Am. Chem. Soc.* 1979, 101, 2201.
- (279) Schuster, G. B.; Lan, J. Y. Presented at the XI IUPAC Symposium on Photochemistry, Lisbon, Portugal, July, 1986; Paper 4P-43.
- (280) Nogami, T.; Hasegawa, Y.; Shiota, Y.; Mikawa, H. *Bull. Chem. Soc. Jpn.* 1975, 48, 3048.
- (281) Ledwith, A. *Acc. Chem. Res.* 1972, 5, 133.
- (282) Mizuno, K.; Ueda, H.; Otsuji, Y. *Chem. Lett.* 1981, 1237 and references therein.
- (283) Mizuno, K.; Hashizume, T.; Otsuji, Y. *J. Chem. Soc., Chem. Commun.* 1983, 772.
- (284) Mattes, S. L.; Farid, S. *J. Am. Chem. Soc.* 1986, 108, 7356.
- (285) Mattes, S. L.; Luss, H. R.; Farid, S. *J. Phys. Chem.* 1983, 87, 4779.
- (286) Tsuchida, A.; Yamamoto, M.; Nishijima, Y. *J. Chem. Soc., Perkin Trans. 2* 1986, 239.
- (287) Roth, H. D.; Schilling, M. L. M.; Jones, G. *J. Am. Chem. Soc.* 1981, 103, 1246.
- (288) Yamamoto, M.; Yoshikawa, H.; Gotoh, T.; Nishijima, Y. *Bull. Chem. Soc. Jpn.* 1983, 56, 2531.
- (289) Mattes, S. L.; Farid, S. *J. Chem. Soc., Chem. Commun.* 1980, 126.
- (290) Engels, R.; Schafer, H. J.; Steckhan, E. *Liebigs Ann. Chem.* 1977, 204.
- (291) Farouk, S.; Hartman, S. E.; Evans, T. R. In *The Exciplex*; Gordon, U., Ware, W. R., Eds.; Academic: New York, 1975; p 327.
- (292) Pac, C.; Oktsuki, T.; Fukunaga, T.; Yanagida, S.; Sakurai, H.; *Chem. Lett.* 1985, 1855.
- (293) Yamashita, Y.; Yaegashi, H.; Mukai, T. *Tetrahedron Lett.* 1985, 3579.
- (294) Mukai, T.; Sato, K.; Yamashita, Y. *J. Am. Chem. Soc.* 1981, 103, 670.
- (295) Hasegawa, E.; Mukai, T. *Bull. Chem. Soc. Jpn.* 1985, 58, 3391.
- (296) Mitzner, R.; Bendig, J.; Kreysig, D. *Z. Chem.* 1986, 26, 255.
- (297) Barber, R. A.; de Mayo, P.; Okada, K.; Wong, S. K. *J. Am. Chem. Soc.* 1982, 104, 4995.
- (298) Mizuno, K.; Murakami, K.; Kaiyama, N.; Otsuji, Y. *J. Chem. Soc., Chem. Commun.* 1983, 462.
- (299) Mijima, T.; Pac, C.; Nakasone, A.; Sakurai, H. *J. Am. Chem. Soc.* 1981, 103, 4499.
- (300) Schaap, A. P.; Lopez, L.; Gagnon, S. D. *J. Am. Chem. Soc.* 1983, 105, 663.
- (301) Schaap, A. P.; Siddiqui, S.; Prasad, G.; Palomino, E.; Lopez, L. *J. Photochem.* 1984, 25, 167.
- (302) Hashimoto, S.; Kurimoto, I.; Fujii, Y.; Noyori, R. *J. Am. Chem. Soc.* 1985, 107, 1427.
- (303) (a) Mariano, P. S.; Stavinoha, J.; Bay, E. *Tetrahedron* 1981, 37, 3385. (b) Mariano, P. S. *Ibid.* 1983, 39, 3845.
- (304) Buchardt, O., Ed. *Photochemistry of Heterocyclic Compounds*; Wiley: New York, 1976 and references therein.
- (305) Horspool, W. H., Ed. *Synthetic Organic Photochemistry*; Plenum: New York, 1984; Chapters 5 and 6 and references therein.
- (306) McCullough, J. J.; Wu, W. S.; Huang, C. W. *J. Chem. Soc., Perkin Trans. 2* 1972, 371.
- (307) Bryce-Smith, D. *Pure Appl. Chem.* 1968, 16, 147 and references therein.
- (308) Yamaski, K.; Matsuura, T.; Saito, I. *J. Chem. Soc., Chem. Commun.* 1974, 944.
- (309) Ito, Y.; Matsuura, T. *J. Org. Chem.* 1979, 44, 41.
- (310) (a) Julian, D. R.; Foster, R. *J. Chem. Soc., Chem. Commun.* 1973, 311. (b) Ikeda, M.; Ohno, K.; Shin-ichiro, M.; Takahashi, M.; Timura, Y. *J. Chem. Soc., Perkin Trans. 2* 1984, 405.
- (311) Davis, P. D.; Neckers, D. C. *J. Org. Chem.* 1980, 45, 456.
- (312) Davis, P. D.; Neckers, D. C.; Blount, J. R. *J. Org. Chem.* 1980, 45, 462.
- (313) Blaunstein, R. P.; Gant, K. S. *Photochem. Photobiol.* 1973, 18, 347.
- (314) Paquette, L. A.; Slomp, G. *J. Am. Chem. Soc.* 1963, 85, 765. Taylor, E. C.; Kan, R. O. *Ibid.* 1963, 85, 776.
- (315) Srinivasan, R., Ed. *Org. Photochem. Synth.* 1976, 2, 5.
- (316) Bendig, J.; Buchwitz, W.; Fischer, J.; Kreysig, D. *J. Prakt. Chem.* 1981, 323, 485. See also: Julian, D. R., ref 304, Chapter 9.
- (317) Lablance-Comber, A. In ref 304, Chapter 4.
- (318) For a recent example see: Gotthardt, H.; Schenk, K. H. *J. Chem. Soc., Chem. Commun.* 1986, 687.
- (319) Kaneko, C.; Naito, T.; Somei, M. *J. Chem. Soc., Chem. Commun.* 1979, 804.
- (320) (a) Kaneko, C.; Shimomura, N.; Momose, Y.; Naito, T. *Chem. Lett.* 1983, 1239. (b) Kaneko, C.; Katagiri, N.; Uchiyama, K.; Yamada, T. *Chem. Pharm. Bull.* 1985, 33, 4160.
- (321) Barlow, M. G.; Brown, D. E.; Haszeldine, R. N. *J. Chem. Soc., Chem. Commun.* 1977, 669.
- (322) Barlow, M. G.; Haszeldine, R. N.; Langridge, J. R. *J. Chem. Soc., Chem. Commun.* 1979, 608.
- (323) Caronna, T.; Morrochi, S.; Traldi, P.; Vittimberga, B. M. *J. Chem. Soc., Chem. Commun.* 1979, 64.
- (324) Saito, I.; Shimozone, K.; Miyazahi, S.; Matsuura, T.; Fukuyama, K.; Katsube, Y. *Tetrahedron Lett.* 1980, 2317.
- (325) Wexler, A. J.; Hyatt, J. A.; Reynolds, P. W.; Cottrell, C.; Swenton, J. S. *J. Am. Chem. Soc.* 1978, 100, 512.
- (326) Savino, T. G.; Konicki, C. L.; Swenton, J. S. *Tetrahedron Lett.* 1983, 4055.
- (327) Krauch, C. H.; Metzner, W.; Schenck, G. O. *Chem. Ber.* 1966, 99, 1723.
- (328) Takamatsu, K.; Ryang, H.-S.; Sakurai, H. *J. Chem. Soc., Chem. Commun.* 1973, 903.

- (329) Rivas, C.; Payo, E.; Mantecon, J.; Cortez, L. *Photochem. Photobiol.* **1968**, *7*, 807.
- (330) Jones, G. *Org. Photochem.* **1981**, *5*, 1.
- (331) Leon, V.; Bolivar, R. A.; Tasayco, M. L.; Gonzalez, R.; Rivas, C. *Org. Magn. Reson.* **1983**, *21*, 470 and references therein.
- (332) Pacheco, D.; Rivas, C.; Vargas, F. *J. Heterocycl. Chem.* **1983**, *20*, 1465.
- (333) Tinnemans, A. H. A.; Neckers, D. C. *J. Org. Chem.* **1978**, *43*, 2493.
- (334) Sindler-Kylyk, M.; Neckers, D. C.; Blount, J. R. *Tetrahedron* **1981**, *37*, 3377.
- (335) Kirby, N. V.; Reid, S. T. *J. Chem. Soc., Chem. Commun.* **1980**, 150.
- (336) Fery-Forgues, S.; Paillous, N. *J. Org. Chem.* **1986**, *51*, 672.
- (337) Kawamura, Y.; Kumagai, T.; Mukai, T. *Chem. Lett.* **1985**, 1937.
- (338) Nalini, V.; Desiraju, G. R. *J. Chem. Soc., Chem. Commun.* **1986**, 1030.
- (339) Lim, E. C. *Acc. Chem. Res.* **1987**, *20*, 8.
- (340) Lim, E. C.; Locke, R. J.; Lim, E. T.; Fujioka, T.; Iwamura, H. *J. Phys. Chem.* **1987**, *91*, 1298.
- (341) Johnston, L. J.; Scaiano, J. C.; Wilson, T. *J. Am. Chem. Soc.* **1987**, *109*, 1509.
- (342) Hara, K.; Yano, H. *J. Phys. Chem.* **1986**, *90*, 4265.
- (343) Zachariasse, K.; Kuhnle, W.; Weller, A. *Chem. Phys. Lett.* **1980**, *73*, 6.
- (344) Georgescauld, D.; Desmasz, J. P.; Lapouyade, R.; Babeau, A.; Richard, H.; Winnik, U. *Photochem. Photobiol.* **1980**, *31*, 539.
- (345) Reda, F.; Spink, C. *J. Phys. Chem.* **1987**, *91*, 1628.
- (346) Clements, U. T. U.; McMurray, T. B. H. *J. Chem. Soc., Chem. Commun.* **1986**, 1104.
- (347) Olmsted, J.; Meyer, T. J. *J. Phys. Chem.* **1987**, *91*, 1649.